

รพ. ศิริราช ปิยมหาราชการุณย์ กรุงเทพมหานคร ประเทศไทย

15th. FLOOR WARD ROOM

MATERIALS & MILLWORK SPECIFICATION
FIXED GOODS SPECIFICATION
LOOSE SPECIFICATION

ISSUED DATE 2020 MAR 02

(แผนนกรรมการวัสดุ ของโครงการ)

Leo International Design Group Co., Ltd.
39th Floor, Ocean Tower II Building
75/108 -109 Sukhumvit 19 Road
Klongtoey Nua, Vadhana
Bangkok 10110, Thailand
Tel : +66 (0) 2281 7733
Fax : +66 (0) 2281 7734
E-mail : lidg@lidg.co.th
www.lidg.co.th

INTERIOR ARCHITECTURE
DESIGNER

LEOINTER

39th Floor Ocean Tower II Building

75/108 -109 Sukhumvit 19 Road, Klongtoey Nua, Vadhana, Bangkok 10110, Thailand.

Tel : +66 (0) 2261 7733 Fax : +66 (0) 2261 7734 Email : lidgATlidg.co.th

Project :

รพ. ศิริราช ปิยมหาราชการุณย์ กรุงเทพฯ ประเทศไทย
15th. FLOOR WARD ROOM

Date :

ISSUED
2020 MAR 02

CONTENT PAGE

A. GENERIC SPECIFICATION – VOLUME 1, 2, 3

(REFER TO LEO INTERNATIONAL DESIGN GROUP CO.,LTD. SPECIFICATION)

B. FF&E GENERAL SPECIFICATIONS

1.0 MATERIALS & MILLWORK SPECIFICATION

- 1.1 CEILING SPECIFICATION
- 1.2 CARPET SPECIFICATION
- 1.3 GLASS/MIRROR SPECIFICATION
- 1.4 LAMINATE SPECIFICATION
- 1.5 METAL/STAINLESS STEEL SPECIFICATION
- 1.6 PAINT SPECIFICATION
- 1.7 STONE/TILE SPECIFICATION
- 1.8 WALL COVERING/WALL PADDING SPECIFICATION
- 1.9 TIMBER/ VENEER WOOD SPECIFICATION
- 1.10 OTHER MATERIALS SPECIFICATION
- 1.11 VINYL SPECIFICATION

2.0 FIXED GOODS SPECIFICATION

- 2.1 ELETRICAL FITTING SPECIFICATION
- 2.2 SANITARY SPECIFICATION
- 2.3 DOOR/IRONMONGERY SPECIFICATION
- 2.4 GENERAL LIGHTING SPECIFICATION

3.0 LOOSEGOODS SPECIFICATION

- 3.1 FURNITURE SPECIFICATION
- 3.2 LIGHTING SPECIFICATION
- 3.3 TEXTILE SPECIFICATION
- 3.4 RUG SPECIFICATION
- 3.5 ARTWORK SPECIFICATION

1. MATERIALS & MILLWORK SPECIFICATION

รพ. ศิริราช ปิยมหาราชการุณย์ กรุงเทพมหานคร ประเทศไทย

PROPOSED INTERIOR FIT-OUT

FOR

15th. FLOOR WARD ROOM

INTERIOR ARCHITECTURE
DESIGNER

LEOINTER

39th Floor Ocean Tower II Building

75/108 -109 Sukhumvit 19 Road, Klongtoey Nua, Vadhana, Bangkok 10110, Thailand.

Tel : +66 (0) 2261 7733 Fax : +66 (0) 2261 7734 Email : lidgATlidg.co.th

Project :

รพ. ศิริราช ปิยมหาราชการุณย์ กรุงเทพมหานคร ประเทศไทย
15th. FLOOR WARD ROOM

Date :

ISSUED
2020 MAR 02

MATERIALS & MILLWORK SPECIFICATION DATA SHEET

CONTENTS

1.1 CEILING SPECIFICATION

CL-01	GYPSUM CEILING BOARD	1.1 – 01
CL-02	GYPSUM CEILING BOARD – MOISTURE RESISTANCE	1.1 – 02

1.2 CARPET SPECIFICATION -

1.3 GLASS/MIRROR SPECIFICATION

GL-01	CLEAR MIRROR	1.3-01
-------	--------------	--------

1.4 LAMINATE SPECIFICATION

LM-01	LAMINATE FOR FIX DECORATION	1.4-01
LM-01A	LAMINATE FOR FIX DECORATION	1.4-01A
LM-02	LAMINATE FOR FIX DECORATION	1.4-02
LM-03	LAMINATE FOR FIX DECORATION	1.4-03
LM-04	LAMINATE FOR IN SIDED FIXED DECORATION	1.4 - 04

1.5 METAL SPECIFICATION

MT-01	ALLOY SKIRTING TO WALL FINISH AT WARD ROOM	1.5-01
-------	--	--------

1.6 PAINT SPECIFICATION

PT-01	EMULSION PAINT TO CEILING	1.6-01
PT-02	EMULSION PAINT TO WALL	1.6-02

1.7 STONE / TILE / MOSAIC SPECIFICATION

ST-01	ARTIFICIAL STONE TO TOP	1.7A - 01
TL-01	TILE TO WALL FINISH AT TOILET WARD ROOM	1.7B-01
TL-02	TILE TO WALL FINISH AT TOILET WARD ROOM	1.7B-02

1.8 WALLCOVERING/WALL PADDING SPECIFICATION

1.9 TIMBER / WOOD SPECIFICATION -

1.10 OTHER MATERIALS SPECIFICATION-

OM-01	WALL CAPPING AND COVE FILLET	1.10-01
OM-02	STAINLESS STEEL CORNER GUARDS	1.10-02
OM-03	ROCK WOOL SOUND INSULATION	1.10-03

1.11 VINYL FLOOR SPECIFICATION

VI-01	VINYL FLOOR AT WARD ROOM	1.11-01
VI-02	VINYL FLOOR AT WARD ROOM	1.11-02
VI-03	VINYL FLOOR AT WARD ROOM	1.11-03

1.1 CEILING SPECIFICATION

รพ. ศิริราช ปิยมหาราชการุณย์ กรุงเทพมหานคร ประเทศไทย

PROPOSED INTERIOR FIT-OUT

FOR

15th. FLOOR WARD ROOM

Project :	รพ. ศิริราช ปิยมหาราชการุณย์ กรุงเทพฯ ประเทศไทย 15th. FLOOR WARD ROOM	Date :	ISSUED 2020 MAR 02
------------------	---	---------------	------------------------------



StandardBoard

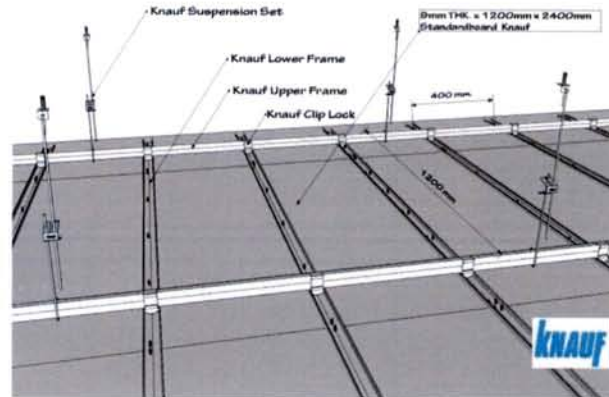

Board Material

Knauf StandardBoard

Material : 100% Natural Gypsum
Dimension : 9mm x 1200mm x 2400mm
RH : up to 90%

Fixing

The distance from board to metal frame follow through Knauf recommendation outline in Installation Manual

Screw

Drywall screw, length 25 mm

Finishing

Knauf Joint Tape and Joint Compound, for detailing finishing application follow the recommendation of Knauf described in Installation Manual

Frame

Lower Frame

Metal Frame, range 400mm c/c
Hot dip galvanized with a thick of layer with minimum G500 referered to ASTM A653 thick 0.50mm - BMT
Dimension 38mm x 16mm x 3000mm

Upper Frame

Metal Frame, range 1200mm c/c
Hot dip galvanized with a thick of layer with minimum G500 referered to ASTM A653 thick 0.50mm - BMT
Dimension 38mm x 16mm x 3000mm

Accessories

Saddle Clip, Threaded Rod, Soffit Cleat and Wall Angle etx.,

Item	Description	Source	Remarks
GYPSUM CEILING BOARD ฝ้าเพดานยิปซัมบอร์ด หนา 9 มม.ชนิดขอบลาด พร้อมโครงคร่าวจาบเรียบ ทาสี	MODEL : STANDARD GYPSUM BOARD KNAUF COLOUR/FINISH : PAINT COAT PT-101 SIZE: 1200 x 2400 x 9 mm. THK. ,	KNAUF GYPSUM (THAILAND) LTD. CONTACT : MS. KAMONWAN TEL : +662 689 6077 FAX : +662 689 6011 MOBILE : +66 0 65 521-4842 E-MAIL : buachoo.kamonwan@knauf.co.th WEBSITE : www.knauf.co.th	REFER DETAIL TO SAMPLE MATERIAL FOR LIDG. APPROVAL

Instructions:

- All quantities to be verified by manufacturer/ installer.
- 30cm.x30cm. finish samples to be submitted by manufacturer for LIDG's approval prior to production.
- Manufacturer warrants all products from all defects and guarantees to replace any or all parts should they prove deficient within one year from date of owner's acceptance. All costs in this regard shall be borne by the manufacturer.
- All supplied items must be of contract quality and suitable for commercial use.

Project :	รพ. ศิริราช ปิยมหาราชการุณย์ กรุงเทพมหานคร ประเทศไทย 15th. FLOOR WARD ROOM	Date :	ISSUED 2020 MAR 02
------------------	--	---------------	------------------------------



MoistShield

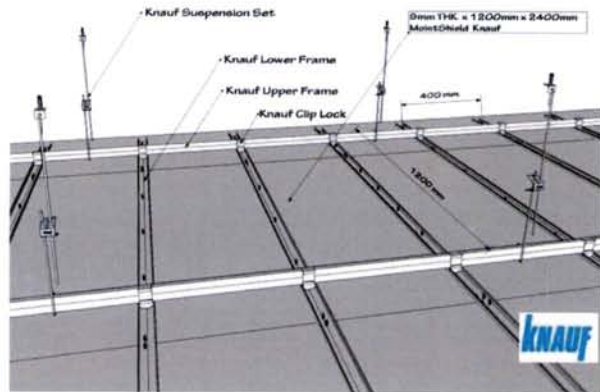

Board Material

Knauf MoistShield

Material : 100% Natural Gypsum
Dimension : 9mm x 1200mm x 2400mm
RH : up to 90%

Fixing

The distance from board to metal frame follow through Knauf recommendation outline in Installation Manual

Screw

Drywall screw, length 25 mm

Finishing

Knauf Joint Tape and Joint Compound, for detailing finishing application follow the recommendation of Knauf described in Installation Manual

Frame

Lower Frame

Metal Frame, range 400mm c/c
Hot dip galvanized with a thick of layer with minimum G500 referered to ASTM A653 thick 0.50mm - BMT
Dimension 38mm x 16mm x 3000mm

Upper Frame

Metal Frame, range 1200mm c/c
Hot dip galvanized with a thick of layer with minimum G500 referered to ASTM A653 thick 0.50mm - BMT
Dimension 38mm x 16mm x 3000mm

Accessories

Saddle Clip, Threaded Rod, Soffit Cleat and Wall Angle etx.,

Item	Description	Source	Remarks
GYPSUM CEILING BOARD MOISTURE RESISTANCE ฝ้าเพดานยิปซัมบอร์ด หนา 9 มม. ชนิดทน ความชื้นพร้อมโครงโครง ฉาบเรียบทาสี AT TOILET ROOM	MODEL : MOISTSHIELD GYPSUM BOARD KNAUF COLOUR/FINISH : PAINT COAT PT-101 SIZE: 1200 x 2400 x 9 mm. THK. ,	KNAUF GYPSUM (THAILAND) LTD. CONTACT : MS. KAMONWAN TEL : +662 689 6077 FAX : +662 689 6011 MOBILE : +66 0 65 521-4842 E-MAIL : buachoo.kamonwan@knauf.co.th WEBSITE : www.knauf.co.th	REFER DETAIL TO SAMPLE MATERIAL FOR LIDG. APPROVAL

Instructions:

- All quantities to be verified by manufacturer/ installer.
- 30cm.x30cm. finish samples to be submitted by manufacturer for LIDG's approval prior to production.
- Manufacturer warrants all products from all defects and guarantees to replace any or all parts should they prove deficient within one year from date of owner's acceptance. All costs in this regard shall be borne by the manufacturer.
- All supplied items must be of contract quality and suitable for commercial use.

1.3 GLASS/MIRROR SPECIFICATION

รพ. ศิริราช ปิยมหาราชการุณย์ กรุงเทพมหานคร ประเทศไทย

PROPOSED INTERIOR FIT-OUT

FOR

15th. FLOOR WARD ROOM

Project :	รพ. ศิริราช ปิยมหาราชการุณย์ กรุงเทพฯ ประเทศไทย 15th. FLOOR WARD ROOM	Date :	ISSUED 2020 MAR 02
------------------	---	---------------	------------------------------

*** PLEASE REFER TO SAMPLE MATERIAL



Item	Description	Source	Remarks
CLEAR MIRROR	MODEL : CLEAR MIRROR COLOUR/FINISH : - SIZE : 6 mm.THK. TO BE TREATED WITH ANTI-RUST BACKING TREATMENT	TO BID	REFER TO SAMPLE MATERIAL FOR LIDG. APPROVAL

Instructions:

1. All quantities to be verified by manufacturer/ installer.
2. Dimensions are subject to change as a result of perfecting the prototype.
3. All glass to be tempered and shall comply with all the applicable codes.
4. Glass to be of accurate size with clean undamaged edges and surfaces which are not disfigured.
5. 30cm.x30cm. glass samples to be provided by manufacturer for LIDG's approval prior to production.
6. Reproducible shop drawings to be provided by manufacturer for LIDG's approval prior to production.
7. All supplied items must be of contract quality and suitable for commercial use.

1.4 LAMINATE SPECIFICATION

รพ. ศิริราช ปิยมหาราชการุณย์ กรุงเทพมหานคร ประเทศไทย

PROPOSED INTERIOR FIT-OUT

FOR

15th. FLOOR WARD ROOM

Project :	รพ. ศิริราช ปิยมหาราชการุณย์ กรุงเทพฯ ประเทศไทย 15th. FLOOR WARD ROOM	Date :	ISSUED 2020 MAR 02
------------------	---	---------------	------------------------------

*** PLEASE REFER TO SAMPLE MATERIAL

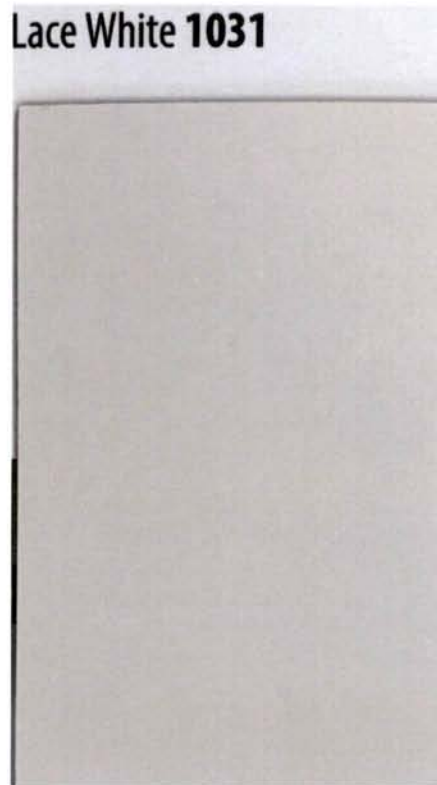

Item	Description	Source	Remarks
ลามิเนตตกแต่งผนังใน ห้องพักรักษาผู้ป่วย LAMINATE FOR FIXED DECORATION AT WARD ROOM	MODEL: 1031 COLOUR/FINISH : LACE WHITE SIZE: REFER TO DRAWING	SIAM STYLAM CO.,LTD. [FINENEZZ] CONTACT : CHITCHANOK Tax ID : 0105559131937 Mobile : 063 445-3999 E-mail : chitchanok@siamstylam.com www.siamstylam.com	REFER DETAIL TO SAMPLE MATERIAL FOR LIDG. APPROVAL

Instructions:

1. All quantities are to be verified by the manufacturer / installer.
2. 30 cm x 30 cm finish samples are to be submitted by the manufacturer for LIDG's approval prior to production.
3. Manufacturer warrants all products from all defects and guarantees to replace any or all parts should they prove deficient, within one year from date of owner's acceptance. All costs in this regard shall be borne by the manufacturer.
4. All supplied items must be of contract quality and suitable for commercial use.

Project :	รพ. ศิริราช ปิยมหาราชการุณย์ กรุงเทพมหานคร ประเทศไทย 15th. FLOOR WARD ROOM	Date :	ISSUED 2020 MAR 02
------------------	--	---------------	------------------------------

*** PLEASE REFER TO SAMPLE MATERIAL

Creamy White 1005

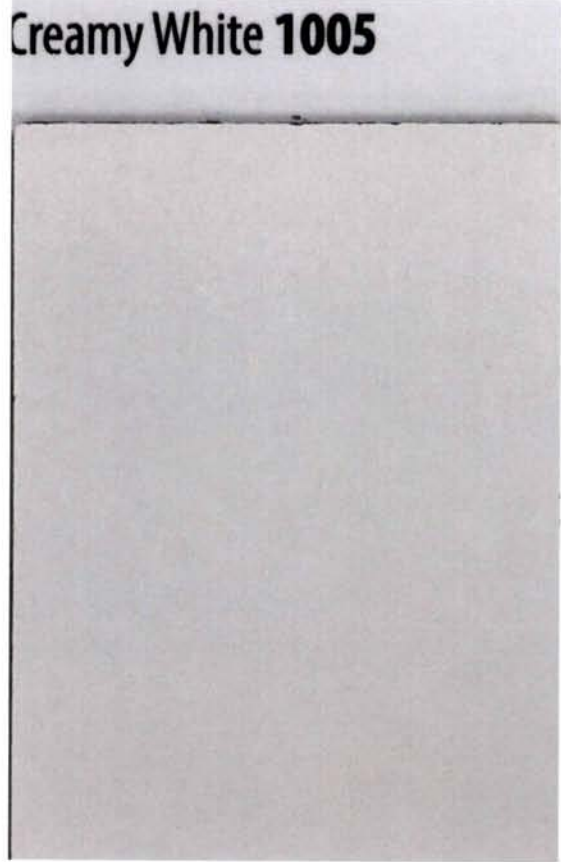

Item	Description	Source	Remarks
ลามิเนตตกแต่งผนังใน ห้องพักรักษาผู้ป่วย LAMINATE FOR FIXED DECORATION AT WARD ROOM	MODEL: 1005 COLOUR/FINISH : CREAMY WHITE SIZE: REFER TO DRAWING	SIAM STYLAM CO.,LTD. [FINENEZZ] CONTACT : CHITCHANOK Tax ID : 0105559131937 Mobile : 063 445-3999 E-mail : chitchanok@siamstylam.com www.siamstylam.com	REFER DETAIL TO SAMPLE MATERIAL FOR LIDG. APPROVAL

Instructions:

1. All quantities are to be verified by the manufacturer / installer.
2. 30 cm x 30 cm finish samples are to be submitted by the manufacturer for LIDG's approval prior to production.
3. Manufacturer warrants all products from all defects and guarantees to replace any or all parts should they prove deficient, within one year from date of owner's acceptance. All costs in this regard shall be borne by the manufacturer.
4. All supplied items must be of contract quality and suitable for commercial use.

Project :	รพ. ศิริราช ปิยมหาราชการุณย์ กรุงเทพฯ ประเทศไทย 15th. FLOOR WARD ROOM	Date :	ISSUED 2020 MAR 02
------------------	---	---------------	------------------------------

*** PLEASE REFER TO SAMPLE MATERIAL



Item	Description	Source	Remarks
ลามิเนตตกแต่งผนังใน ห้องพักรักษาผู้ป่วย LAMINATE FOR FIXED DECORATION AT WARD ROOM	MODEL: GREENLAM COLOUR/FINISH : SY2 5354 SIZE: REFER TO DRAWING	GREENLAM ASIA PACIFIC [THAILAND]CO.,LTD. CONTACT : KATTAREEYA Tel : 02 294-2569 Fax : 02 294-2568 Mobile : 084 081-1422 E-mail : kattareeya.th@greenlam.com www.greenlam.com	REFER DETAIL TO SAMPLE MATERIAL FOR LIDG. APPROVAL

Instructions:

1. All quantities are to be verified by the manufacturer / installer.
2. 30 cm x 30 cm finish samples are to be submitted by the manufacturer for LIDG's approval prior to production.
3. Manufacturer warrants all products from all defects and guarantees to replace any or all parts should they prove deficient, within one year from date of owner's acceptance. All costs in this regard shall be borne by the manufacturer.
4. All supplied items must be of contract quality and suitable for commercial use.

Project :	รพ. ศิริราช ปิยมหาราชการุณย์ กรุงเทพมหานคร ประเทศไทย 15th. FLOOR WARD ROOM	Date :	ISSUED 2020 MAR 02
------------------	--	---------------	------------------------------

*** PLEASE REFER TO SAMPLE MATERIAL

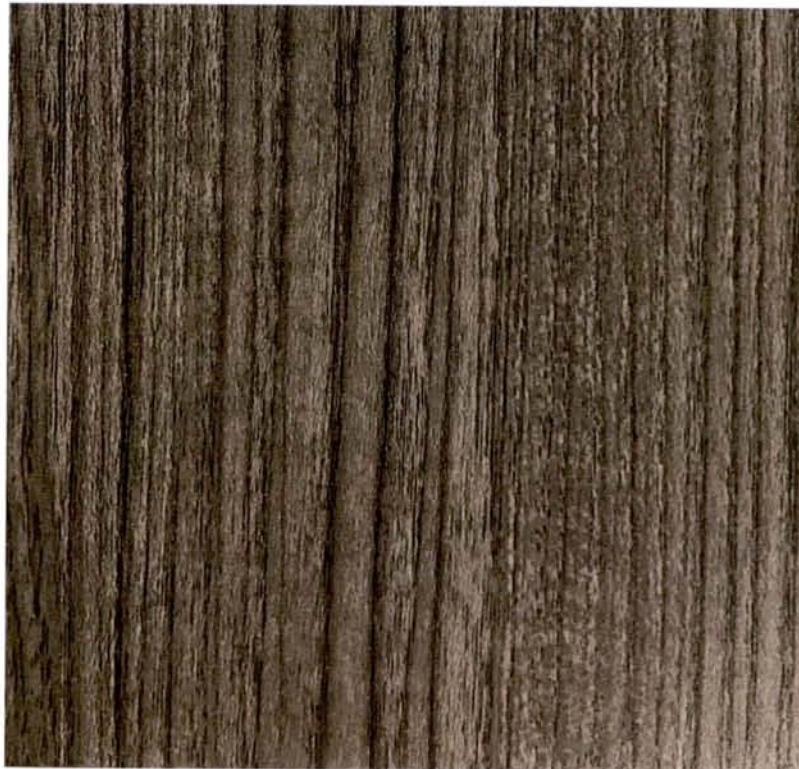

Item	Description	Source	Remarks
ลามิเนตตกแต่งหน้าบาน อ่างล้างมือห้องน้ำ ในห้องพักรักษาผู้ป่วย LAMINATE FOR FIXED DECORATION AT WARD ROOM	MODEL: NEW MIKA COLOUR/FINISH : NWB-3155 SIZE: REFER TO DRAWING	GREENLAM ASIA PACIFIC [THAILAND]CO.,LTD. CONTACT : KATTAREEYA Tel : 02 294-2569 Fax : 02 294-2568 Mobile : 084 081-1422 E-mail : kattareeya.th@greenlam.com www.greenlam.com	REFER DETAIL TO SAMPLE MATERIAL FOR LIDG. APPROVAL

Instructions:

1. All quantities are to be verified by the manufacturer / installer.
2. 30 cm x 30 cm finish samples are to be submitted by the manufacturer for LIDG's approval prior to production.
3. Manufacturer warrants all products from all defects and guarantees to replace any or all parts should they prove deficient, within one year from date of owner's acceptance. All costs in this regard shall be borne by the manufacturer.
4. All supplied items must be of contract quality and suitable for commercial use.

Project :	รพ. ศิริราช ปิยมหาราชการุณย์ กรุงเทพมหานคร ประเทศไทย 15th. FLOOR WARD ROOM	Date :	ISSUED 2020 MAR 02
------------------	--	---------------	------------------------------

*** PLEASE REFER TO SAMPLE MATERIAL

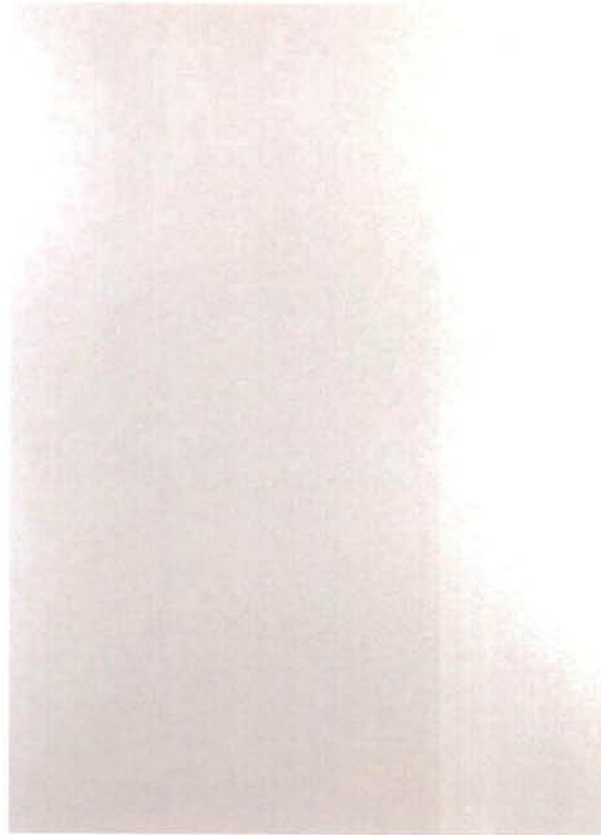

Item	Description	Source	Remarks
ลามิเนตกรุภายในตู้หัวไป LAMINATE FOR IN SIDED FIXED DECORATION	MODEL: K9002S COLOUR/FINISH : WHITE SIZE: REFER TO DRAWING	TAK PRODUCTS & SERVICES CO.,LTD. 8 th FLOOR UNIT 2 SUPALAI GRAND TOWER 1011 RAMA 3 ROAD, CHONG NON-SRI YANAWA BANGKOK 10120 THAILAND CONTACT : MS.SUPAPORN [GAIL] TEL : 662 683 0080 FAX : 662 683 0084 MOBILE : 668 9762-7525 E-MAIL : supaporn@takproducts.co.th	REFER DETAIL TO SAMPLE MATERIAL FOR LIDG. APPROVAL

Instructions:

1. All quantities are to be verified by the manufacturer / installer.
2. 30 cm x 30 cm finish samples are to be submitted by the manufacturer for LIDG's approval prior to production.
3. Manufacturer warrants all products from all defects and guarantees to replace any or all parts should they prove deficient, within one year from date of owner's acceptance. All costs in this regard shall be borne by the manufacturer.
4. All supplied items must be of contract quality and suitable for commercial use.

1.5 METAL SPECIFICATION

รพ. ศิริราช ปิยมหาราชการุณย์ กรุงเทพมหานคร ประเทศไทย

PROPOSED INTERIOR FIT-OUT

FOR

15th. FLOOR WARD ROOM

Project :	รพ. ศิริราช ปิยมหาราชการุณย์ กรุงเทพมหานคร ประเทศไทย 15th. FLOOR WARD ROOM	Date :	ISSUED 2020 MAR 02
------------------	--	---------------	------------------------------

*** PLEASE REFER TO SAMPLE MATERIAL



คิ้วอลูมิเนียมตดกแต่งผนัง U-Wall Code.A04

ลักษณะเป็นคิ้วตัว U แบบไม่มีปีก ขนาด 0.5 เซนฯ ผลิตด้วยอลูมิเนียม alloy ที่ได้คุณภาพผ่านขบวนการทำสีแบบ อะโนไดซ์ เหมาะสำหรับตดกแต่งผนังปูนหรือผนังไม้ปิดผิวพอร์เมก้า

คุณสมบัติเด่นของคิ้วอลูมิเนียมตดกแต่งผนัง

Item	Description	Source	Remarks
คิ้วอลูมิเนียมตดกแต่งผนัง ALLOY SKIRTING TO WALL FINISH AT WARD ROOM	MODEL: U-WALL COLOUR/FINISH : A-04 SIZE : REFER TO DRAWING	ALLOY DEVELOPING WORKPLACE SOLUTIONS FOR THE FUTURE CONTACT : BANCHA Tel : 02-683-4900 Fax : 02-683-4949 Mobile : +668 2486-3818 E-mail : bancha@buildersmart.com	REFER DETAIL TO SAMPLE MATERIAL FOR LIDG. APPROVAL

Instructions:

- All quantities to be verified by manufacturer/ installer.
- 30cm.x30cm. finish samples to be submitted by manufacturer for LIDG's approval prior to production.
- Manufacturer warrants all products from all defects and guarantees to replace any or all parts should they prove deficient within one year from date of owner acceptance. All costs in this regard shall be borne by the manufacturer.
- All supplied items must be of contract quality and suitable for commercial use.

1.6 PAINT SPECIFICATION

รพ. ศิริราช ปิยมหาราชการุณย์ กรุงเทพมหานคร ประเทศไทย

PROPOSED INTERIOR FIT-OUT

FOR

15th. FLOOR WARD ROOM

Project :	รพ. ศิริราช ปิยมหาราชการุณย์ กรุงเทพมหานคร ประเทศไทย 15th. FLOOR WARD ROOM	Date :	ISSUED 2020 MAR 02
------------------	--	---------------	------------------------------

*** PLEASE REFER TO SAMPLE MATERIAL

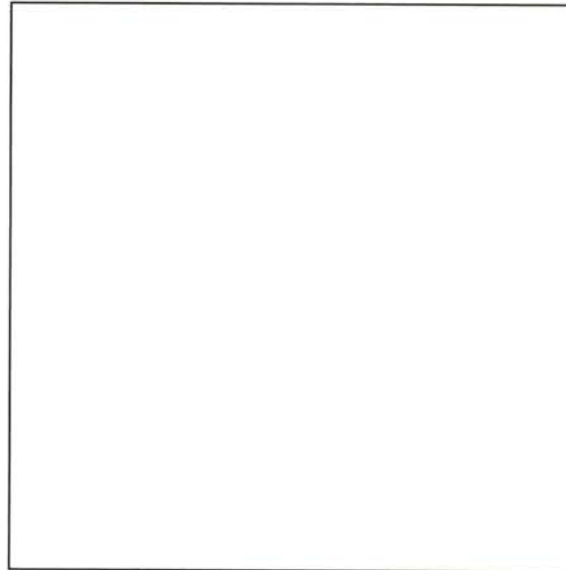

RECOMMENDED COATING SYSTEM:

- 1 COAT OF WATER BASED SEALER
- 2 FINISHING COATS OF SELECTED PAINT

Item	Description	Source	Remarks
งานทาสีน้ำอะคริลิกทา ฝ้าเพดานทั่วไป EMULSION PAINT TO CEILING FINISH	MODEL: -SUPERSHIELD DURACLEAN TO CEILING COLOUR/FINISH : TOA 7252 / SEMI-GLOSS	TOA PAINT (THAILAND) CO.,LTD. CONTACT : PHIRAWAN TEL : +66 2 335 5555 ต่อ 3221 FAX : +66 2 312 8906 MOBILE : +66 84 387 8594 E-MAIL : phirawan.toa@gmail.com WEBSITE : www.toagroup.com	REFER DETAIL TO SAMPLE MATERIAL FOR LIDG. APPROVAL

Instructions:

1. All quantities to be verified by manufacturer/ installer.
2. 30cm.x 30cm. finish samples to be submitted by manufacturer for LIDG's approval prior to production.
3. All selected colours and finishes are to be approved by LIDG and provision must be made for the execution of patterns for trial at designated areas on the Site if required or upon request.
4. Background preparation for paint finish:
 - Uneven plaster wall to be treated with skim coating to make good flat surface.
 - ½" or ¾" thickness plywood of Grade 2 with timber backing to make good flat surface finishing.
5. All surfaces shall be cleaned, dry and free from dirt, oil, grease or foreign matter. Paint shall not be applied to any surfaces upon which there is moisture and not under proper room temperature.
6. Manufacturer warrants all products from all defects and guarantees to replace any or all parts should they prove to deficient within one year from date of owner's acceptance. All costs in this regard shall be borne by the manufacturer.
7. All supplied items must be of contract quality and suitable for commercial use.

Project :	รพ. ศิริราช ปิยมหาราชการุณย์ กรุงเทพมหานคร ประเทศไทย 15th. FLOOR WARD ROOM	Date :	ISSUED 2020 MAR 02
------------------	---	---------------	-------------------------------------

*** PLEASE REFER TO SAMPLE MATERIAL

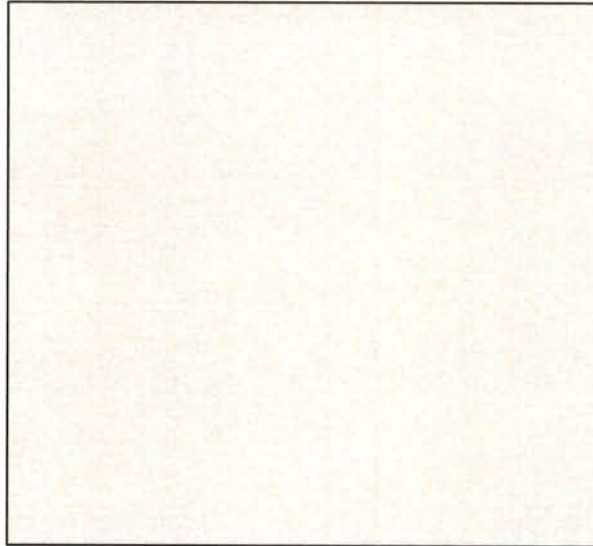

RECOMMENDED COATING SYSTEM:

- 1 COAT OF WATER BASED SEALER
- 2 FINISHING COATS OF SELECTED PAINT

Item	Description	Source	Remarks
งานทาสีน้ำอะคริลิกบนผนังภายในห้องพัก EMULSION PAINT TO WALL FINISH	MODEL: SUPERSHIELD DURACLEAN OXYGEN PLUS COLOUR/FINISH : TOA 7324 SEMI-GLOSS	TOA PAINT (THAILAND) CO.,LTD. CONTACT : PHIRAWAN TEL : +66 2 335 5555 ต่อ 3221 FAX : +66 2 312 8906 MOBILE : +66 84 387 8594 E-MAIL : phirawan.toa@gmail.com WEBSITE : www.toagroup.com	REFER DETAIL TO SAMPLE MATERIAL FOR LIDG. APPROVAL

Instructions:

1. All quantities to be verified by manufacturer/ installer.
2. 30cm.x 30cm. finish samples to be submitted by manufacturer for LIDG's approval prior to production.
3. All selected colours and finishes are to be approved by LIDG and provision must be made for the execution of patterns for trial at designated areas on the Site if required or upon request.
4. Background preparation for paint finish:
 - Uneven plaster wall to be treated with skim coating to make good flat surface.
 - ½" or ¾" thickness plywood of Grade 2 with timber backing to make good flat surface finishing.
5. All surfaces shall be cleaned, dry and free from dirt, oil, grease or foreign matter. Paint shall not be applied to any surfaces upon which there is moisture and not under proper room temperature.
6. Manufacturer warrants all products from all defects and guarantees to replace any or all parts should they prove to deficient within one year from date of owner's acceptance. All costs in this regard shall be borne by the manufacturer.
7. All supplied items must be of contract quality and suitable for commercial use.

1.7 STONE/TILE/MOSAIC SPECIFICATION

รพ. ศิริราช ปิยมหาราชการุณย์ กรุงเทพมหานคร ประเทศไทย

PROPOSED INTERIOR FIT-OUT

FOR

15th. FLOOR WARD ROOM

Project :	รพ. ศิริราช ปิยมหาราชการุณย์ กรุงเทพมหานคร ประเทศไทย 15th. FLOOR WARD ROOM	Date :	ISSUED 2020 MAR 02
------------------	--	---------------	------------------------------

*** PLEASE REFER TO SAMPLE MATERIAL



Item	Description	Source	Remarks
หินเทียมมรกตท็อปเคาเตอร์ ข้างล้างมือ ในห้องพัก ผู้ป่วย ARTIFICIAL STONE TO TOP COUNTER AT WARD ROOM	MODEL: MAE 003 SUPER COLOUR/FINISH: SMOOTH POLISHTED SIZE: REFERED TO DRAWINGS	RAINBOW ENTERPRISE MARKETING GROUP CO.,LTD. [MASTER QUARTZ BY] CONTACT : MANATCHANAN TEL : +66 2 153-8687 MOBILE : +66 94 494-9907 E-MAIL : rmg.bkk@gmail.com	REFER DETAIL TO SAMPLE MATERIAL FOR LIDG. APPROVAL

Instructions:

1. All quantities to be verified by manufacturer/ installer.
2. All selected marble and stone finishes to be preselected from GRADE 1 range with minimum variation and submit for LIDG approval.
3. Manufacturer to submit approved samples of mosaic, marble and stone finishes of 600mm.x600mm. and presented to LIDG's for approval prior to production.
4. Reproducible shop drawings to be provided by manufacturer for approval by LIDG prior to production.
5. Contractor to pre-assemble the pre-selected GRADE 1 hard finishes on site if required or upon request.
6. Contractor to provide approved sealer to selected hard finishes where applicable.
7. Sealer shall be 'SCL-Stain X-seal' or other approved equivalent sealer with the same properties as follows:
 - a. A solvent -based impregnator which repels water and oil-based liquids.
 - b. Allow stone to breathe and release moisture in the stone.
 - c. Applicable on polished marble, granite, limestone, sandstone, slate, terrazzo and homogenous tiles.
 - d. Retain the original look of the natural stones without changing the colors and textures of the stones.
8. Contractor to provide approved grouting colors to match selected marble and stones.
9. Contractor to use white adhesives for laying of selected mosaic in order to enhance the depth of their colors.
10. Selected marble, granite and mosaic of any one colors, finish or pattern shall be obtained from one manufacturer.
11. Damaged and/or defective tiles shall be removed and replaced with new tiles at the Contractor's cost and expense.
12. All supplied items must be of contract quality and suitable for commercial use
13. Top/Floors standard: All porous stone must be properly sealed upon installation. Where natural stone, granite or similar approved tops are specified, a sub top of 12mm. plywood must be provided

Project :	รพ. ศิริราช ปิยมหาราชการุณย์ กรุงเทพมหานคร ประเทศไทย 15th. FLOOR WARD ROOM	Date :	ISSUED 2020 MAR 02
------------------	--	---------------	------------------------------

*** PLEASE REFER TO SAMPLE MATERIAL

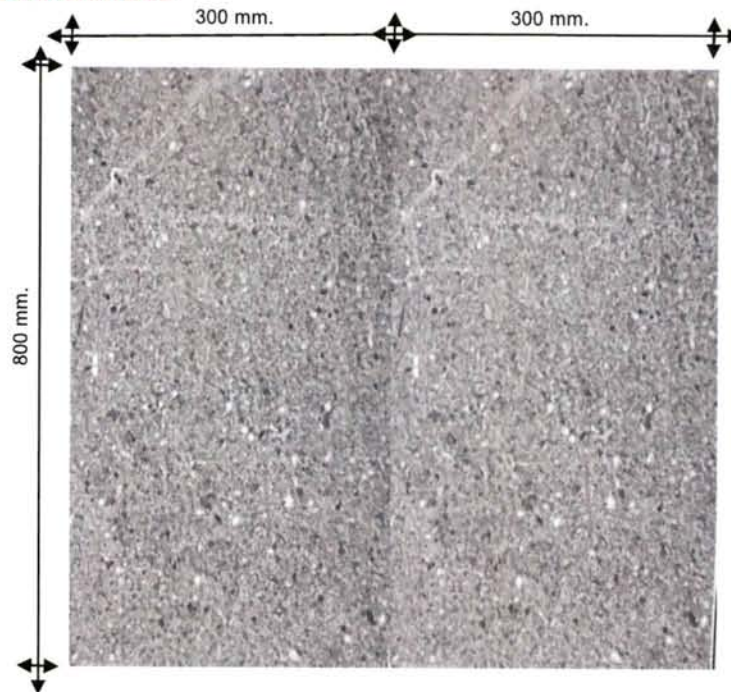

Item	Description	Source	Remarks
กระเบื้องตกแต่งผนังใน ห้องน้ำ ห้องพักรักษาผู้ป่วย TILE TO WALL FINISH AT TOILET WARD ROOM	MODEL: WL SULLIVAN COLOUR/FINISH: BROWN-01 POLISHED SIZE: 300 X 800 MM, REFERRED TO DRAWINGS	ARTIFACT PORCELAIN TILE CO.,LTD. CONTACT: K.MINTRA MOBILE : 087-504-2882 TEL. 662 718 0411-3 FAX. 662 718 0414 E-MAIL: -	REFER TO SAMPLE MATERIAL FOR LIDG. APPROVAL

Instructions:

1. All quantities to be verified by manufacturer/ installer.
2. All selected marble and stone finishes to be preselected from GRADE 1 range with minimum variation and submit for LIDG' approval.
3. Manufacturer to submit approved samples of mosaic, marble and stone finishes of 600mm.x600mm. and presented to LIDG's for approval prior to production.
4. Reproducible shop drawings to be provided by manufacturer for approval by LIDG prior to production.
5. Contractor to pre-assemble the pre-selected GRADE 1 hard finishes on site if required or upon request.
6. Contractor to provide approved sealer to selected hard finishes where applicable.
7. Sealer shall be 'SCL-Stain X-seal' or other approved equivalent sealer with the same properties as follows:
 - a. A solvent -based impregnator which repels water and oil-based liquids.
 - b. Allow stone to breathe and release moisture in the stone.
 - c. Applicable on polished marble, granite, limestone, sandstone, slate, terrazzo and homogenous tiles.
 - d. Retain the original look of the natural stones without changing the colors and textures of the stones.
8. Contractor to provide approved grouting colors to match selected marble and stones.
9. Contractor to use white adhesives for laying of selected mosaic in order to enhance the depth of their colors.
10. Selected marble, granite and mosaic of any one colors, finish or pattern shall be obtained from one manufacturer.
11. Damaged and/or defective tiles shall be removed and replaced with new tiles at the Contractor's cost and expense.
12. All supplied items must be of contract quality and suitable for commercial use
13. Top/Floors standard: All porous stone must be properly sealed upon installation. Where natural stone, granite or similar approved tops are specified, a sub top of 12mm. plywood must be provided

Project :	รพ. ศิริราช ปิยมหาราชการุณย์ กรุงเทพฯ ประเทศไทย 15th. FLOOR WARD ROOM	Date :	ISSUED 2020 MAR 02
------------------	---	---------------	------------------------------

*** PLEASE REFER TO SAMPLE MATERIAL

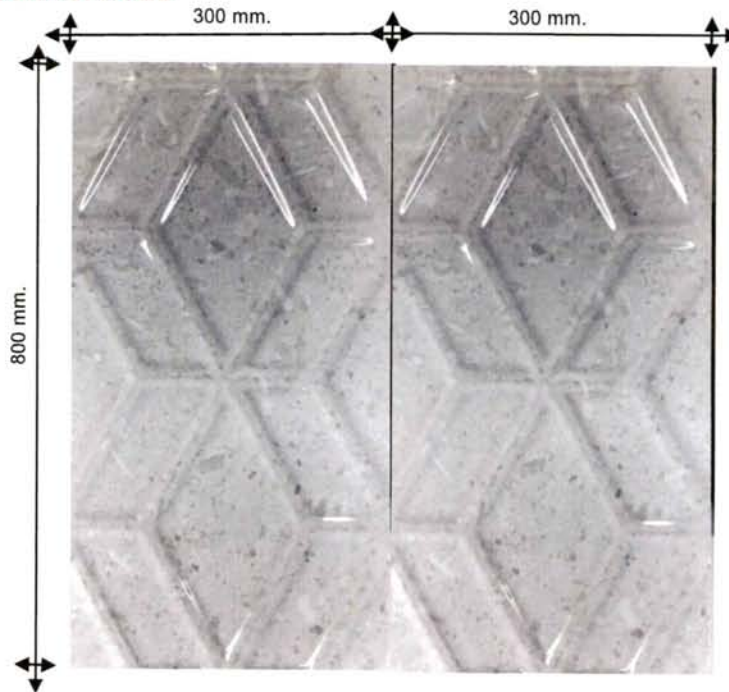

Item	Description	Source	Remarks
กระเบื้องตกแต่งผนังใน ห้องน้ำ ห้องพักรักษาผู้ป่วย TILE TO WALL FINISH AT TOILET WARD ROOM	MODEL: WL. ETNA 01R COLOUR/FINISH: POLISHED SIZE: 300 X 800 MM, REFERRED TO DRAWINGS	ARTIFACT PORCELAIN TILE CO.,LTD. CONTACT: K.MINTRA MOBILE : 087-504-2882 TEL. 662 718 0411-3 FAX. 662 718 0414 E-MAIL: -	REFER TO SAMPLE MATERIAL FOR LIDG. APPROVAL

Instructions:

1. All quantities to be verified by manufacturer/ installer.
2. All selected marble and stone finishes to be preselected from GRADE 1 range with minimum variation and submit for LIDG' approval.
3. Manufacturer to submit approved samples of mosaic, marble and stone finishes of 600mm.x600mm. and presented to LIDG's for approval prior to production.
4. Reproducible shop drawings to be provided by manufacturer for approval by LIDG prior to production.
5. Contractor to pre-assemble the pre-selected GRADE 1 hard finishes on site if required or upon request.
6. Contractor to provide approved sealer to selected hard finishes where applicable.
7. Sealer shall be 'SCL-Stain X-seal' or other approved equivalent sealer with the same properties as follows:
 - a. A solvent -based impregnator which repels water and oil-based liquids.
 - b. Allow stone to breathe and release moisture in the stone.
 - c. Applicable on polished marble, granite, limestone, sandstone, slate, terrazzo and homogenous tiles.
 - d. Retain the original look of the natural stones without changing the colors and textures of the stones.
8. Contractor to provide approved grouting colors to match selected marble and stones.
9. Contractor to use white adhesives for laying of selected mosaic in order to enhance the depth of their colors.
10. Selected marble, granite and mosaic of any one colors, finish or pattern shall be obtained from one manufacturer.
11. Damaged and/or defective tiles shall be removed and replaced with new tiles at the Contractor's cost and expense.
12. All supplied items must be of contract quality and suitable for commercial use
13. Top/Floors standard: All porous stone must be properly sealed upon installation. Where natural stone, granite or similar approved tops are specified, a sub top of 12mm. plywood must be provided

1.9 TIMBER/VENEER WOOD SPECIFICATION

รพ. ศิริราช ปิยมหาราชการุณย์ กรุงเทพมหานคร ประเทศไทย

PROPOSED INTERIOR FIT-OUT

FOR

15th. FLOOR WARD ROOM

1.10 OTHER MATERIALS SPECIFICATION

รพ. ศิริราช ปิยมหาราชการุณย์ กรุงเทพมหานคร ประเทศไทย

PROPOSED INTERIOR FIT-OUT

FOR

15th. FLOOR WARD ROOM

Project :	รพ. ศิริราช ปิยมหาราชการุณย์ กรุงเทพมหานคร ประเทศไทย 15th. FLOOR WARD ROOM	Date :	ISSUED 28 FEBRUARY 2020
------------------	--	---------------	-----------------------------------

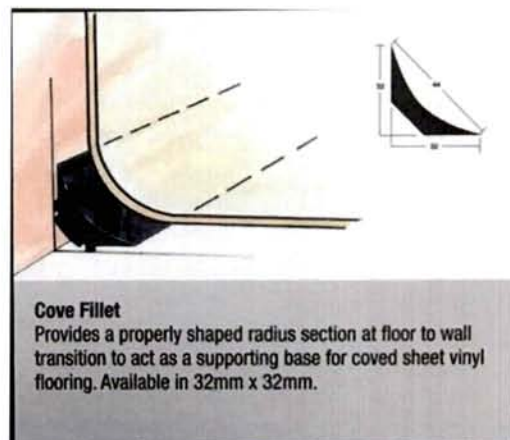
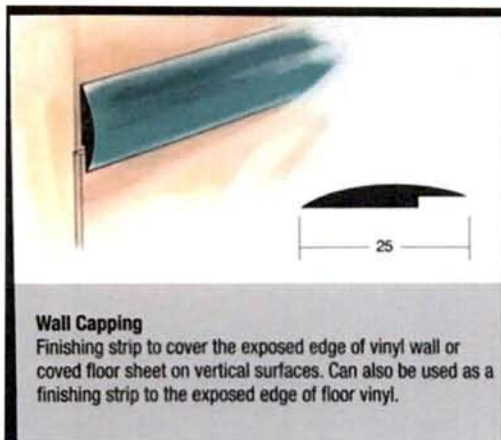
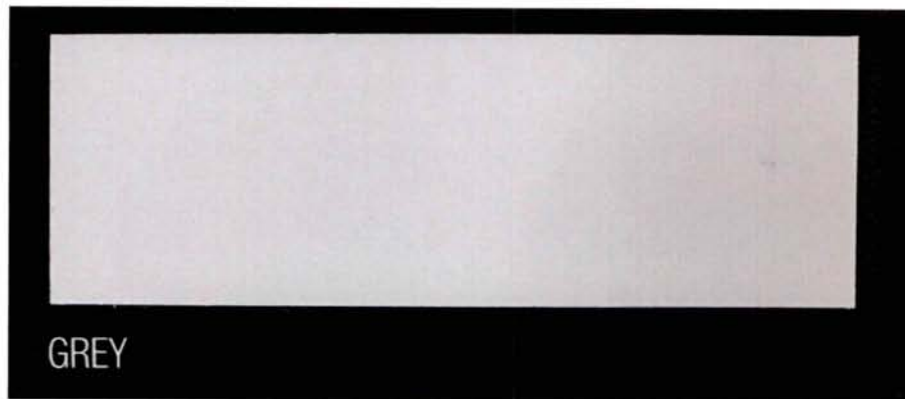

Item	Description	Source	Remarks
วัสดุ ตัวรองมุมพื้นและ ตัวจบ ขอบพื้นกระเบื้อง ไวนิล WALL CAPPING AND COVE FILLET	MODEL: WALL CAPPING AND COVE FILLET COLOUR/FINISH : BLACK SIZE: REFER TO DRAWING	VISPACK CO.,LTD. CONTACT: MR.SASITHORN TEL: 662 315 9189 FAX : 662 316 5381 MOBILE: 668 6882 9721 EMAIL: marketing@vispack.com	REFER TO SAMPLE MATERIAL FOR SUPPLIERS

Instructions:

- All quantities to be verified by manufacturer/ installer.
- 30cm.x30cm. finish samples to be submitted by manufacturer for LIDG's approval prior to production.
- Adhesives used must not be diluted and shall be approved by Manufacturer.
- All specified wall coverings to be flame retardant & obtain at least class '0' on contract quality goods.
- Manufacturer warrants all products from all defects and guarantees to replace any or all parts should they prove deficient within one year from date of owner's acceptance. All costs in this regard shall be borne by the manufacturer.
- All supplied items must be of contract quality and suitable for commercial use.

Project :	รพ. ศิริราช ปิยมหาราชการุณย์ กรุงเทพมหานคร ประเทศไทย 15th. FLOOR WARD ROOM	Date :	ISSUED 28 FEBRUARY 2020
------------------	--	---------------	-----------------------------------

*** PLEASE REFER TO SAMPLE MATERIAL

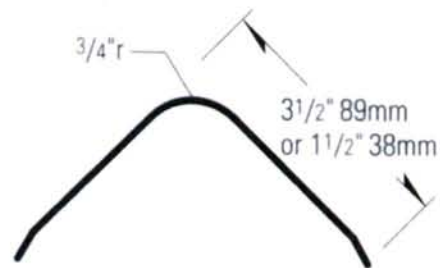
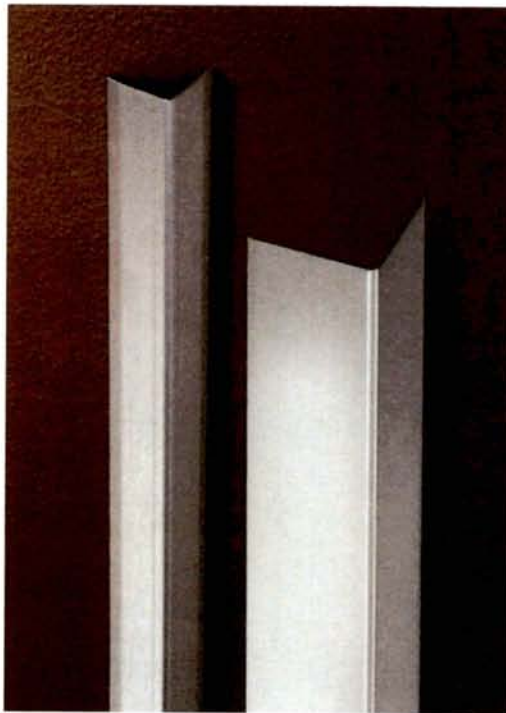

Custom: Stainless Steel Only

Item	Description	Source	Remarks
คิ้วกันกระแทก บริเวณ ทางเดิน STAINLESS STEEL CORNER GUARDS	MODEL: CORNER GUARDS COLOUR/FINISH : 181128 SIZE: REFERED TO DRAWINGS	TEO HONG SILOM CO.,LTD. CONTACT : KANJANA TEL : +662 2312-0045 FAX : +662 2751-9450 MOBILE : +668 6991-1997 E-MAIL : kanjana.s@teohong.com WEBSITE : www.teohong.com	REFER TO SAMPLE MATERIAL FOR SUPPLIERS

Instructions:

1. All quantities to be verified by manufacturer/ installer.
2. 30cm.x30cm, finish samples to be submitted by manufacturer for LIDG's approval prior to production.
3. Adhesives used must not be diluted and shall be approved by Manufacturer.
4. All specified wall coverings to be flame retardant & obtain at least class '0' on contract quality goods.
5. Manufacturer warrants all products from all defects and guarantees to replace any or all parts should they prove deficient within one year from date of owner's acceptance. All costs in this regard shall be borne by the manufacturer.
6. All supplied items must be of contract quality and suitable for commercial use.

Project :	รพ. ศิริราช ปิยมหาราชการุณย์ กรุงเทพมหานคร ประเทศไทย 15th. FLOOR WARD ROOM	Date :	ISSUED 28 FEBRUARY 2020
------------------	--	---------------	-----------------------------------

*** PLEASE REFER TO SAMPLE MATERIAL



Item	Description	Source	Remarks
วัสดุฉนวนใยหินกันเสียง กันรามไฟ ROCK WOOL หนา 75 มม. โนนังยิปซัมบอร์ด ROCK WOOL SOUND INSULATION	MODEL: SAFE SILENT PRO COLOUR/FINISH : PRO-330 SIZE: REFERED TO DRAWINGS	ROCKWOOL [THAILAND] LIMITED CONTACT : KANTISA TEL : +662 731-7511-4 FAX : +662 731-7510 MOBILE : +66 92 272-3132 E-MAIL : -	REFER TO SAMPLE MATERIAL FOR SUPPLIERS

Instructions:

- All quantities to be verified by manufacturer/ installer.
- 30cm.x30cm. finish samples to be submitted by manufacturer for LIDG's approval prior to production.
- Adhesives used must not be diluted and shall be approved by Manufacturer.
- All specified wall coverings to be flame retardant & obtain at least class '0' on contract quality goods.
- Manufacturer warrants all products from all defects and guarantees to replace any or all parts should they prove deficient within one year from date of owner's acceptance. All costs in this regard shall be borne by the manufacturer.
- All supplied items must be of contract quality and suitable for commercial use.

1.11 VINYL FLOOR SPECIFICATION

รพ. ศิริราช ปิยมหาราชการุณย์ กรุงเทพมหานคร ประเทศไทย

PROPOSED INTERIOR FIT-OUT

FOR

15th. FLOOR WARD ROOM

Project :	รพ. ศิริราช ปิยมหาราชการุณย์ กรุงเทพฯ ประเทศไทย 15th. FLOOR WARD ROOM	Date :	ISSUED 28 FEBRURY 2020
------------------	---	---------------	----------------------------------

*** PLEASE REFER TO SAMPLE MATERIAL

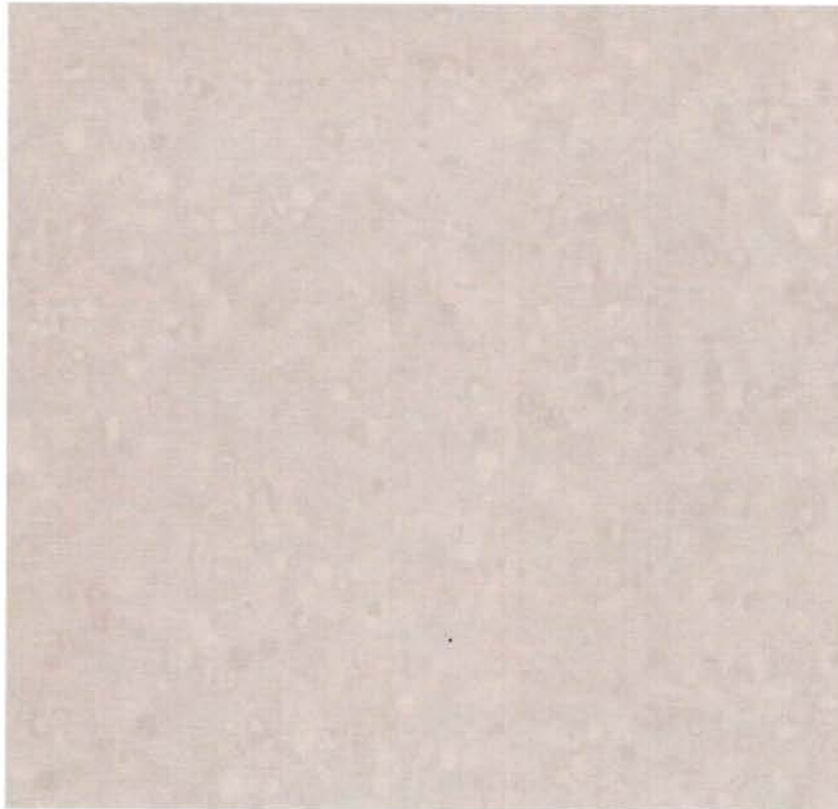

Item	Description	Source	Remarks
พื้นกระเบื้องยางแบบ ม้วนใช้ภายในห้องพัก ผู้ป่วย VINYL FLOOR AT WARD ROOM	MODEL : VINYL FLOOR CODE : 50018 MORTAR SIZE : 25M. X 200 CM. 2.0THK. NCS S 1005-Y10R /LRV 70 REFER TO DRAWING	TEO HONG SILOM CO.,LTD. (BANGKOK, THAILAND) CONTACT: MS.ANGKANA TEL: 662 312 0045-69EXT.1618 FAX : 662 751 9450 MOBILE: 668 9131 9990 EMAIL: angkana@teohong.com	REFER DETAIL TO SAMPLE MATERIAL FOR LIDG. APPROVAL

Instructions:

1. All quantities to be verified by manufacturer/ installer.
2. 30cm.x30cm. finish samples to be submitted by manufacturer for LIDG's approval prior to production.
3. Adhesives used must not be diluted and shall be approved by Manufacturer.
4. All specified wall coverings to be flame retardant & obtain at least class '0' on contract quality goods.
5. Manufacturer warrants all products from all defects and guarantees to replace any or all parts should they prove deficient within one year from date of owner's acceptance. All costs in this regard shall be borne by the manufacturer.
6. All supplied items must be of contract quality and suitable for commercial use.

Project :	รพ. ศิริราช ปิยมหาราชการุณย์ กรุงเทพมหานคร ประเทศไทย 15th. FLOOR WARD ROOM	Date :	ISSUED 28 FEBRURY 2020
------------------	--	---------------	----------------------------------

*** PLEASE REFER TO SAMPLE MATERIAL



Item	Description	Source	Remarks
พื้นกระเบื้องยางลายไม้ แบบม้วนใช้ภายใน ห้องพักรักษาผู้ป่วย VINYL FLOOR AT WARD ROOM	MODEL : FORBO CODE : SARLON OAK 428483 SIZE : 25M. X 200 CM. 2.6 THK REFER TO DRAWING	TEO HONG SILOM CO.,LTD. (BANGKOK, THAILAND) CONTACT: MS.ANGKANA TEL: 662 312 0045-69EXT.1618 FAX : 662 751 9450 MOBILE: 668 9131 9990 EMAIL: angkana@teohong.com	REFER DETAIL TO SAMPLE MATERIAL FOR LIDG. APPROVAL

Instructions:

1. All quantities to be verified by manufacturer/ installer.
2. 30cm.x30cm. finish samples to be submitted by manufacturer for LIDG's approval prior to production.
3. Adhesives used must not be diluted and shall be approved by Manufacturer.
4. All specified wall coverings to be flame retardant & obtain at least class '0' on contract quality goods.
5. Manufacturer warrants all products from all defects and guarantees to replace any or all parts should they prove deficient within one year from date of owner's acceptance. All costs in this regard shall be borne by the manufacturer.
6. All supplied items must be of contract quality and suitable for commercial use.

Project :	รพ. ศิริราช ปิยมหาราชการุณย์ กรุงเทพมหานคร ประเทศไทย 15th. FLOOR WARD ROOM	Date :	ISSUED 28 FEBRURY 2020
------------------	--	---------------	----------------------------------

*** PLEASE REFER TO SAMPLE MATERIAL

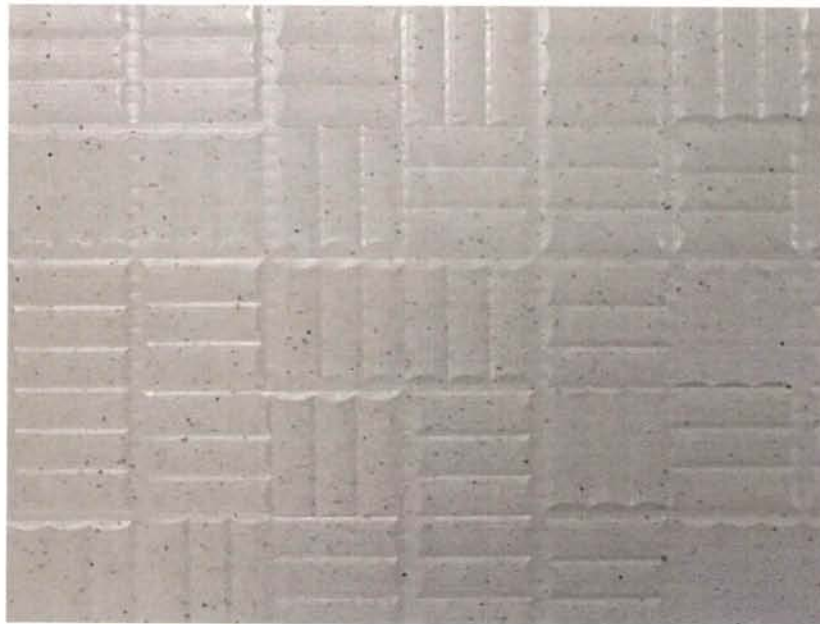

Item	Description	Source	Remarks
พื้นกระเบื้องยางสำหรับพื้น ห้องน้ำ ภายในห้องพัก VINYL FLOOR AT TOILET WARD ROOM	MODEL : BNA-2001 CODE : - SIZE : 1820 MM. X 9M. 2.8THK. REFER TO DRAWING	UNICOM CO.,LTD. CONTACT: MS.THANYAPORN TEL: 662 316 3199 FAX : 662 316 3199 MOBILE: 669 2946 4624 EMAIL: thanyaporn.de@unicom.com.th	REFER DETAIL TO SAMPLE MATERIAL FOR LIDG. APPROVAL

Instructions:

1. All quantities to be verified by manufacturer/ installer.
2. 30cm.x30cm. finish samples to be submitted by manufacturer for LIDG's approval prior to production.
3. Adhesives used must not be diluted and shall be approved by Manufacturer.
4. All specified wall coverings to be flame retardant & obtain at least class '0' on contract quality goods.
5. Manufacturer warrants all products from all defects and guarantees to replace any or all parts should they prove deficient within one year from date of owner's acceptance. All costs in this regard shall be borne by the manufacturer.
6. All supplied items must be of contract quality and suitable for commercial use.

โรงพยาบาล ศิริราชปิยมหาราชการุณย์

ชั้น 15 โซน B

- 2.0 ข้อกำหนดสำหรับเฟอร์นิเจอร์ และของตกแต่ง จำพวกติดผนังหรือเคลื่อนย้ายไม่ได้
- 2.2 ข้อกำหนด งานสุขาภิบาล

ISSUED DATE

02 มีนาคม 2563

INTERIOR ARCHITECTURE
DESIGNER

LEOINTER

Leo International Design Group Co., Ltd.
39th Floor, Ocean Tower 2
75/108-109 Sukhumvit 19 Road
Klongtoey Nua, Vadhana, Bangkok 10110,
Thailand

Tel : +66 (0) 2281 7733

Fax : +66 (0) 2281 7734

E-mail : ildg@ildg.co.th

www.ildg.co.th

Project :	โรงพยาบาล ศิริราช ปิยมหาราชการุณย์ ชั้น 15 โซน B	Date :	ISSUED 02 มีนาคม 2563
------------------	--	---------------	---------------------------------

มาตรฐานการกำหนดข้อมูล

หน้าสารบัญ

ก. ข้อกำหนดทั่วไป

(ตามข้อกำหนดมาตรฐานของบริษัท ลีโล อินเตอร์เน็ทซ์เนล กรุ๊ป)

ข. ข้อกำหนด เฟอร์นิเจอร์ลอยตัว เฟอร์นิเจอร์ติดผนัง และอุปกรณ์ต่าง ๆ

1.0 วัสดุและข้อกำหนดต่าง ๆ

- 1.1 ข้อกำหนด ฝ้าเพดาน
- 1.2 ข้อกำหนด พรม
- 1.3 ข้อกำหนด กระຈก
- 1.4 ข้อกำหนด ลามิเนต
- 1.5 ข้อกำหนด โลหะต่างๆ
- 1.6 ข้อกำหนด สีทาต่างๆ
- 1.7 ข้อกำหนด หินอ่อน / กระเบื้องเซรามิก / กระเบื้องโมเสค
- 1.8 ข้อกำหนด วอลเปเปอร์ / ผ้าและหนังบุผนัง
- 1.9 ข้อกำหนด ไม้เนื้อแข็ง / ไม้จริง
- 1.10 ข้อกำหนด วัสดุและอุปกรณ์อื่นๆ
- 1.11 ข้อกำหนด กระเบื้องยาง

2.0 ข้อกำหนดสำหรับเฟอร์นิเจอร์ และของตกแต่ง จำพวกติดผนัง หรือเคลื่อนย้ายไม่ได้

- 2.1 ข้อกำหนด งานระบบติดตั้งไฟฟ้า
- 2.2 ข้อกำหนด งานสุขาภิบาล
- 2.3 ข้อกำหนด งานประตูหน้าต่าง
- 2.4 ข้อกำหนด งานจัดแสงทั่วไป

3.0 รพ.ศิริราช ปิยมหาราชการุณย์, กรุงเทพฯ, ประเทศไทย

- 3.1 ข้อกำหนด เฟอร์นิเจอร์ลอยตัว
- 3.2 ข้อกำหนด โคมไฟตกแต่ง
- 3.3 ข้อกำหนด ผ้า, สิ่งทอ
- 3.4 ข้อกำหนด พรม
- 3.5 ข้อกำหนด ภาพศิลปะ, ของตกแต่ง

2.0 ข้อกำหนดสำหรับเฟอร์นิเจอร์ และของตกแต่ง

จำพวกติดผนัง หรือเคลื่อนย้ายไม่ได้

สำหรับ

โรงพยาบาล ศิริราช ปิยมหาราชการุณย์

นำเสนอวัสดุในการตกแต่งภายใน

อาคาร ปิยมหาราชการุณย์ ชั้น 15 โซน B

Project :

โรงพยาบาล ศิริราช ปิยมหาราชการุณย์
ชั้น 15 โซน B

Date :

ISSUED

02 มีนาคม 2563

FIXED GOODS SPECIFICATION DATA SHEET

CONTENTS

NOs	TITLE	PAGE
2.2	SANITARY SPECIFICATION	2.2
SN-01	ก๊อกสำหรับอ่างล้างจานแบบก้านโยก	2.2-01
SN-02	สตอปป์วาล์วพร้อมสายอ่อนท่อน้ำดี	2.2-02
SN-03	ชุดท่อน้ำทิ้งอ่างล้างจาน	2.2-03
SN-04	อ่างล้างจานและชุดท่อน้ำทิ้งอ่างล้างจาน	2.2-04
SN-05	ราวมือจับแบบมีปุ่มกันลื่นแบบราวคู่พับได้ W97 X D610 H.184 mm	2.2-05
SN-06	ราวมือจับแบบมีปุ่มกันลื่นรูปทรงตัว "L" W745 X D78 H.750 mm	2.2-06
SN-07	ราวมือจับแบบมีปุ่มกันลื่นแบบราวเดี่ยว W580 X D78 H.80 mm	2.2-07
SN-08	ราวมือจับแบบมีปุ่มกันลื่นแบบราวเดี่ยว W480 X D78.5 H.80 mm	2.2-08
SN-09	ชั้นตะแกรงพร้อมราวแขวนผ้าสแตนเลส	2.2-09
SN-10	ตะขอแขวนผ้า อุปกรณ์ของเดิม	2.2-10
SN-11	ที่แขวนกระดาษชำระ อุปกรณ์ของเดิม	2.2-11
SN-12	ชุดฝักบัวอาบน้ำแบบก้านปรับระดับ อุปกรณ์ของเดิม	2.2-12
SN-13	ชุดสายฉีดชำระ อุปกรณ์ของเดิม	2.2-13
SN-14	ที่วางสบู่ อุปกรณ์ของเดิม	2.2-14
SN-15	โถสุขภัณฑ์ แบบมีหม้อน้ำ อุปกรณ์ของเดิม	2.2-15
SN-16	ชุดสายฉีดชำระ อุปกรณ์ของเดิม	2.2-16
SN-17	ฝาท่อน้ำทิ้ง อุปกรณ์ของเดิม	2.2-17
MR-01	บานกระจกห้องน้ำ	2.2-18

2.2 ข้อกำหนดสำหรับงานสุขาภิบาล

สำหรับ

โรงพยาบาล ศิริราช ปิยมหาราชการุณย์

นำเสนอวัสดุในการตกแต่งภายใน

อาคาร ปิยมหาราชการุณย์ ชั้น 15 โซน B

Project :	โรงพยาบาล ศิริราช ปิยมหาราชการุณย์ ชั้น 15 โซน B	Date :	ISSUED 02 มีนาคม 2563
------------------	--	---------------	---------------------------------

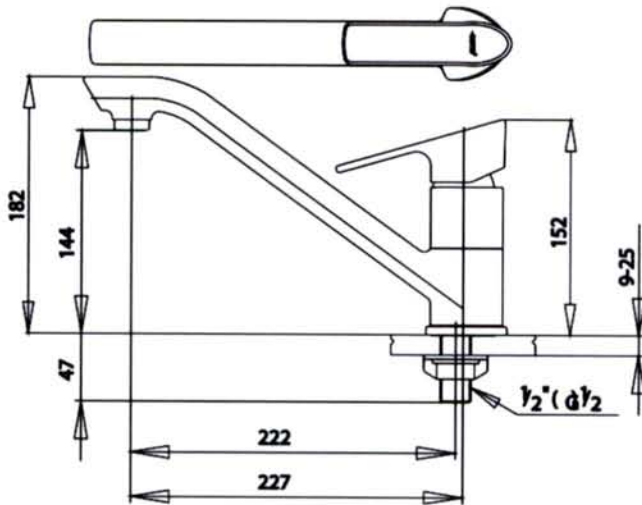

PRODUCT MODEL: CT135F

PRODUCT NAME : ก๊อกอ่างซิงค์แบบก้านโยก

หมายเหตุ: เช็คนขนาดและพื้นที่หน้างานก่อนการติดตั้งทุกครั้ง

Item	Description	Source	Remarks
SN-01 ก๊อกสำหรับอ่างล้างจาน แบบก้านโยก	MODEL: AS SHOWN COLOUR/FINISH: CHROME SIZE: AS SHOWN	SIAM SANITARY WARE CO.,LTD. 36/11 Viphavadee Rangsit Rd , Sanam Bin,Donmuang,Bangkok,Thailand 10210 ATTN: K.MANASSAWEE T (K.PATTZ) M: 092 258 9144 E: manassat@scq.com	

Instructions:

1. All quantities to be verified by manufacturer/ installer.
2. Manufacturer to provide prototype of sanitary wares/fittings and accessories for LIDG 's designer approval prior to production
3. To be international wired for use in Local context.
4. Manufacturer to supply all necessary hardware and instruction for installation of fixture.
5. Manufacturer to co-ordinate all wiring requirements for permanent surface mounting and provide hanging / security details for electrician.
6. Manufacturer warrants all products from all defects and guarantees to replace any or all parts should they prove deficient within one year from date of owner acceptance. All costs in this regard shall be borne by the manufacturer.
7. All supplied items to be contract quality ,suitable for commercial use.

Project :	โรงพยาบาล ศิริราช ปิยมหาราชการุณย์ ชั้น 15 โซน B	Date :	ISSUED 02 มีนาคม 2563
------------------	--	---------------	---------------------------------

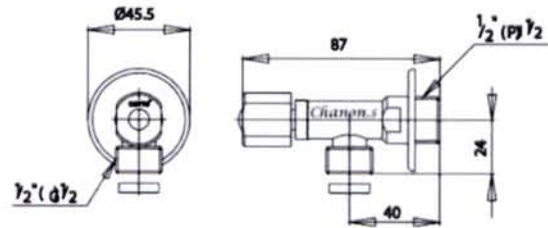

PRODUCT MODEL: CT179(HM)

PRODUCT NAME : วาล์วเปิด - ปิดหน้า 1 ทาง



PRODUCT MODEL: Z404 (HM20")

PRODUCT NAME : สายอ่อนน้ำดี

หมายเหตุ: เช็คนขนาดและพื้นที่หน้างานก่อนการติดตั้งทุกครั้ง

Item	Description	Source	Remarks
SN-02 สตอปวาล์วพร้อมสาย อ่อนท่อน้ำดี	MODEL: AS SHOWN COLOUR/FINISH: CHROME SIZE: AS SHOWN	SIAM SANITARY WARE CO.,LTD. 36/11 Viphavadee Rangsit Rd , Sanam Bin,Donmuang,Bangkok,Thailand 10210 ATTN: K.MANASSAWEE T (K.PATTZ) M: 092 258 9144 E: manassat@scg.com	

Instructions:

- All quantities to be verified by manufacturer/ installer.
- Manufacturer to provide prototype of sanitary wares/fittings and accessories for LIDG 's designer approval prior to production
- To be international wired for use in Local context.
- Manufacturer to supply all necessary hardware and instruction for installation of fixture.
- Manufacturer to co-ordinate all wiring requirements for permanent surface mounting and provide hanging / security details for electrician.
- Manufacturer warrants all products from all defects and guarantees to replace any or all parts should they prove deficient within one year from date of owner acceptance. All costs in this regard shall be borne by the manufacturer.
- All supplied items to be contract quality ,suitable for commercial use.

Project :	โรงพยาบาล ศิริราช ปิยมหาราชการุณย์ ชั้น 15 โซน B	Date :	ISSUED 02 มีนาคม 2563
------------------	--	---------------	---------------------------------



PRODUCT MODEL: P31PP

PRODUCT NAME : ท่อน้ำทิ้งอ่างล้างจานพร้อมชุด
กันกลิ่น ทั้งที่ออกจากผนังและขึ้นจากพื้น



Item	Description	Source	Remarks
SN-03 ชุดท่อน้ำทิ้งอ่างล้างจาน	MODEL: AS SHOWN COLOUR/FINISH: CHROME SIZE: AS SHOWN	PEN K INTER TRADING CO.,LTD. (MEX) ATTN: K. WIPA M: 086-098 3663 T: 02-713-1100 F: 02-381-6614 E: contact2@penk.co.th	

Instructions:

- All quantities to be verified by manufacturer/ installer.
- Manufacturer to provide prototype of sanitary wares/ fittings and accessories for LIDG 's designer approval prior to production
- To be international wired for use in Local context.
- Manufacturer to supply all necessary hardware and instruction for installation of fixture.
- Manufacturer to co-ordinate all wiring requirements for permanent surface mounting and provide hanging / security details for electrician.
- Manufacturer warrants all products from all defects and guarantees to replace any or all parts should they prove deficient within one year from date of owner acceptance. All costs in this regard shall be borne by the manufacturer.
- All supplied items to be contract quality ,suitable for commercial use.

Project :	โรงพยาบาล ศิริราช ปิยมหาราชการุณย์ ชั้น 15 โซน B	Date :	ISSUED 02 มีนาคม 2563
------------------	--	---------------	---------------------------------

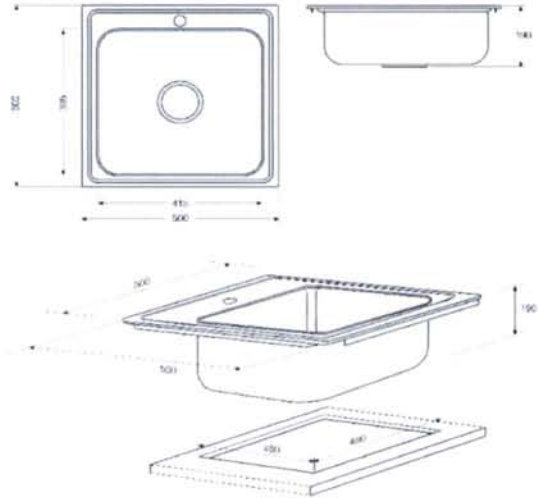

CODE DLS50B **Barcode.8858787010475**
ชื่อ อ่างล้างจาน MEX รุ่น DLS50B (สแตนเลส สตีล)
Name MEX SINK 1 BOWL Mod.DLS50B (S/S)

คุณสมบัติ

- อ่างล้างจาน MEX 1 หลุม สแตนเลส สตีล AISI304.
- ขนาดหลุม : 41.5 x 39.5 ซม.
- หลุมลึก 19 ซม.
- (รวมความสูงขอบอ่างและสคอ)
- สคออย่าง 3 1/2 นิ้ว พร้อมท่อน้ำล้นและท่อกันกลิ่น (P-TRAP).

ข้อมูลทางเทคนิค

ขนาด : กว้าง x ลึก : 50.0 x 50.0 ซม.
 ขนาดเจาะเฟอร์นิเจอร์ : 48.0 x 48.0 ซม.

หมายเหตุ: เช็คนขนาดและพื้นที่หน้างานก่อนการติดตั้งทุกครั้ง

Item	Description	Source	Remarks
SN-04 อ่างล้างจาน และ ชุดท่อน้ำ น้ำทิ้งอ่างล้างจาน	MODEL: AS SHOWN COLOUR/FINISH: CHROME SIZE: AS SHOWN	PEN K INTER TRADING CO.,LTD. (MEX) ATTN: K. WIPA M: 086-098 3663 T: 02-713-1100 F: 02-381-6614 E: contact2@penk.co.th	ไม่รวมก๊อมน้ำ

Instructions:

1. All quantities to be verified by manufacturer/ installer.
2. Manufacturer to provide prototype of sanitary wares/fittings and accessories for LIDG 's designer approval prior to production
3. To be international wired for use in Local context.
4. Manufacturer to supply all necessary hardware and instruction for installation of fixture.
5. Manufacturer to co-ordinate all wiring requirements for permanent surface mounting and provide hanging / security details for electrician.
6. Manufacturer warrants all products from all defects and guarantees to replace any or all parts should they prove deficient within one year from date of owner acceptance. All costs in this regard shall be borne by the manufacturer.
7. All supplied items to be contract quality ,suitable for commercial use.

Project :	โรงพยาบาล ศิริราช ปิยมหาราชการุณย์ ชั้น 15 โซน B	Date :	ISSUED 02 มีนาคม 2563
------------------	--	---------------	---------------------------------

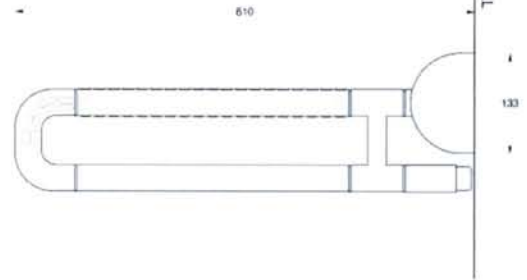
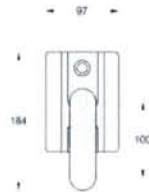

PRODUCT MODEL: ERS34

PRODUCT NAME : ราวมือจับแบบมีปุ่มกันลื่นแบบราวคู่พับได้

W97 X D610 H.184 mm

หมายเหตุ: เช็คนขนาดและพื้นที่หน้างานก่อนการติดตั้งทุกครั้ง

Item	Description	Source	Remarks
SN-05 ราวมือจับแบบมีปุ่มกันลื่นแบบราวคู่พับได้	MODEL: AS SHOWN COLOUR/FINISH: CHROME SIZE: AS SHOWN	Mogen (Thailand) Company Limited. 9 Moo 12, Buengkhamproi, Lamlukka, Pathumthani. 12150 ATTN: K.ORKAMOL T: 02 150 9709-13 M: 095 204 9568 E: ornkamol@mogen.co.th	

Instructions:

- All quantities to be verified by manufacturer/ installer.
- Manufacturer to provide prototype of sanitary wares/fittings and accessories for LIDG 's designer approval prior to production
- To be international wired for use in Local context.
- Manufacturer to supply all necessary hardware and instruction for installation of fixture.
- Manufacturer to co-ordinate all wiring requirements for permanent surface mounting and provide hanging / security details for electrician.
- Manufacturer warrants all products from all defects and guarantees to replace any or all parts should they prove deficient within one year from date of owner acceptance. All costs in this regard shall be borne by the manufacturer.
- All supplied items to be contract quality ,suitable for commercial use.

Project :	โรงพยาบาล ศิริราช ปิยมหาราชการุณย์ ชั้น 15 โซน B	Date :	ISSUED 02 มีนาคม 2563
------------------	--	---------------	---------------------------------

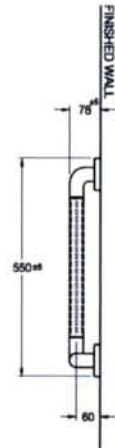
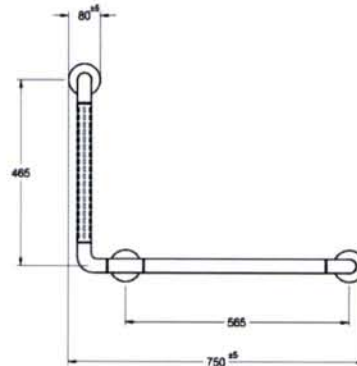

PRODUCT MODEL: ERS01N

PRODUCT NAME : ราวมือจับแบบมีปุ่มกันลื่นรูปทรงตัว "L"

W745 X D78 H.750 mm

หมายเหตุ: เช็คนขนาดและพื้นที่หน้างานก่อนการติดตั้งทุกครั้ง

Item	Description	Source	Remarks
SN-06 ราวมือจับแบบมีปุ่มกันลื่นรูปทรงตัว "L"	MODEL: AS SHOWN COLOUR/FINISH: CHROME SIZE: AS SHOWN	Mogen (Thailand) Company Limited. 9 Moo 12, Buengkhamproi, Lamlukka, Pathumthani. 12150 ATTN: K.ORNKAMOL T: 02 150 9709-13 M: 095 204 9568 E: ornkamol@mogen.co.th	

Instructions:

- All quantities to be verified by manufacturer/ installer.
- Manufacturer to provide prototype of sanitary wares/fittings and accessories for LIDG 's designer approval prior to production
- To be international wired for use in Local context.
- Manufacturer to supply all necessary hardware and instruction for installation of fixture.
- Manufacturer to co-ordinate all wiring requirements for permanent surface mounting and provide hanging / security details for electrician.
- Manufacturer warrants all products from all defects and guarantees to replace any or all parts should they prove deficient within one year from date of owner acceptance. All costs in this regard shall be borne by the manufacturer.
- All supplied items to be contract quality ,suitable for commercial use.

Project :	โรงพยาบาล ศิริราช ปิยมหาราชการุณย์ ชั้น 15 โซน B	Date :	ISSUED 02 มีนาคม 2563
------------------	--	---------------	---------------------------------

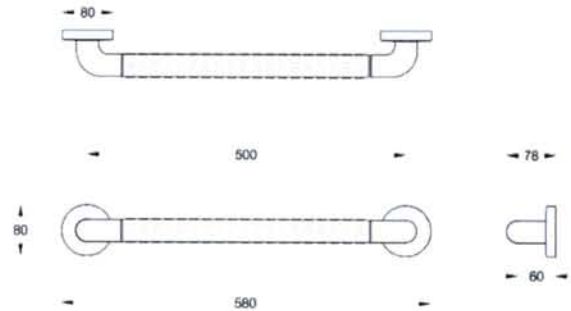

PRODUCT MODEL: ERS15

PRODUCT NAME : ราวมือจับแบบมีปุ่มกันลื่นแบบราวเดี่ยว

W580 X D78 H.80 mm

หมายเหตุ: เช็คนขนาดและพื้นที่หน้างานก่อนการติดตั้งทุกครั้ง

Item	Description	Source	Remarks
SN-07 ราวพยุงตัวรูปทรงตัว "I" ยาว 580 มม.	MODEL: AS SHOWN COLOUR/FINISH: CHROME SIZE: AS SHOWN	Mogen (Thailand) Company Limited. 9 Moo 12, Buengkhamproi, Lamlukka, Pathumthani. 12150 ATTN: K.ORKAMOL T: 02 150 9709-13 M: 095 204 9568 E: orkamol@mogen.co.th	

Instructions:

- All quantities to be verified by manufacturer/ installer.
- Manufacturer to provide prototype of sanitary wares/fittings and accessories for LIDG 's designer approval prior to production
- To be international wired for use in Local context.
- Manufacturer to supply all necessary hardware and instruction for installation of fixture.
- Manufacturer to co-ordinate all wiring requirements for permanent surface mounting and provide hanging / security details for electrician.
- Manufacturer warrants all products from all defects and guarantees to replace any or all parts should they prove deficient within one year from date of owner acceptance. All costs in this regard shall be borne by the manufacturer.
- All supplied items to be contract quality ,suitable for commercial use.

Project :	โรงพยาบาล ศิริราช ปิยมหาราชการุณย์ ชั้น 15 โซน B	Date :	ISSUED 02 มีนาคม 2563
------------------	--	---------------	---------------------------------

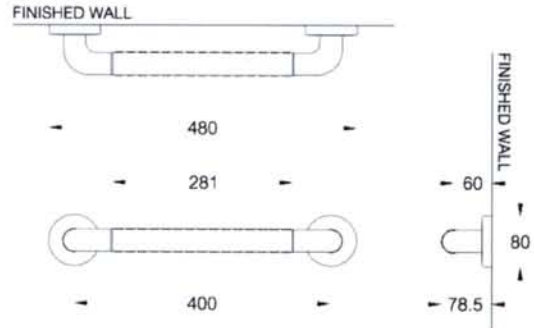

PRODUCT MODEL: ERS15

PRODUCT NAME : ราวมือจับแบบมีปุ่มกันลื่นแบบราวเดี่ยว

W480 X D78.5 H.80 mm

หมายเหตุ: เช็คนขนาดและพื้นที่หน้างานก่อนการติดตั้งทุกครั้ง

Item	Description	Source	Remarks
SN-08 ราวพุงตัวรูปทรงตัว "I" ยาว 480 มม.	MODEL: AS SHOWN COLOUR/FINISH: CHROME SIZE: AS SHOWN	Mogen (Thailand) Company Limited. 9 Moo 12, Buengkhamproi, Lamlukka, Pathumthani. 12150 ATTN: K.ORNKAMOL T: 02 150 9709-13 M: 095 204 9568 E: ornkamol@mogen.co.th	

Instructions:

- All quantities to be verified by manufacturer/ installer.
- Manufacturer to provide prototype of sanitary wares/ fittings and accessories for LIDG 's designer approval prior to production
- To be international wired for use in Local context.
- Manufacturer to supply all necessary hardware and instruction for installation of fixture.
- Manufacturer to co-ordinate all wiring requirements for permanent surface mounting and provide hanging / security details for electrician.
- Manufacturer warrants all products from all defects and guarantees to replace any or all parts should they prove deficient within one year from date of owner acceptance. All costs in this regard shall be borne by the manufacturer.
- All supplied items to be contract quality ,suitable for commercial use.

Project :	โรงพยาบาล ศิริราช ปิยมหาราชการุณย์ ชั้น 15 โซน B	Date :	ISSUED 02 มีนาคม 2563
------------------	--	---------------	---------------------------------

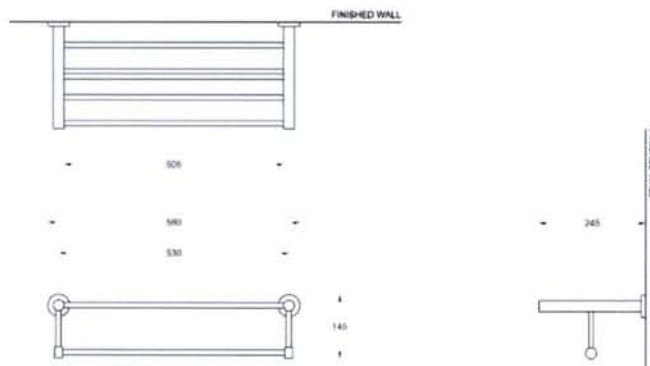

PRODUCT MODEL: ACS1358-3HL

PRODUCT NAME : ชั้นตะแกรงพร้อมราวแขวนผ้าสแตนเลส

หมายเหตุ: เช็คนขนาดและพื้นที่หน้างานก่อนการติดตั้งทุกครั้ง

Item	Description	Source	Remarks
SN-09 ชั้นตะแกรงพร้อมราว แขวนผ้าสแตนเลส	MODEL: AS SHOWN COLOUR/FINISH: CHROME SIZE: AS SHOWN	Mogen (Thailand) Company Limited. 9 Moo 12, Buengkhamproi, Lamlukka, Pathumthani. 12150 ATTN: K.ORNKAMOL T: 02 150 9709-13 M: 095 204 9568 E: ornkamol@mogen.co.th	

Instructions:

- All quantities to be verified by manufacturer/ installer.
- Manufacturer to provide prototype of sanitary wares/fittings and accessories for LIDG 's designer approval prior to production
- To be international wired for use in Local context.
- Manufacturer to supply all necessary hardware and instruction for installation of fixture.
- Manufacturer to co-ordinate all wiring requirements for permanent surface mounting and provide hanging / security details for electrician.
- Manufacturer warrants all products from all defects and guarantees to replace any or all parts should they prove deficient within one year from date of owner acceptance. All costs in this regard shall be borne by the manufacturer.
- All supplied items to be contract quality ,suitable for commercial use.

Project :	โรงพยาบาล ศิริราช ปิยมหาราชการุณย์ ชั้น 15 โซน B	Date :	ISSUED 02 มีนาคม 2563
------------------	---	---------------	---------------------------------

--

Item	Description	Source	Remarks
SN-10 ตะขอแขวนผ้า	MODEL: AS SHOWN COLOUR/FINISH: CHROME SIZE: AS SHOWN		อุปกรณ์ของเดิม

Instructions:

1. All quantities to be verified by manufacturer/ installer.
2. Manufacturer to provide prototype of sanitary wares/fittings and accessories for LIDG 's designer approval prior to production
3. To be international wired for use in Local context.
4. Manufacturer to supply all necessary hardware and instruction for installation of fixture.
5. Manufacturer to co-ordinate all wiring requirements for permanent surface mounting and provide hanging / security details for electrician.
6. Manufacturer warrants all products from all defects and guarantees to replace any or all parts should they prove deficient within one year from date of owner acceptance. All costs in this regard shall be borne by the manufacturer.
7. All supplied items to be contract quality ,suitable for commercial use.

Project :	โรงพยาบาล ศิริราช ปิยมหาราชการุณย์ ชั้น 15 โซน B	Date :	ISSUED 02 มีนาคม 2563
------------------	---	---------------	---------------------------------

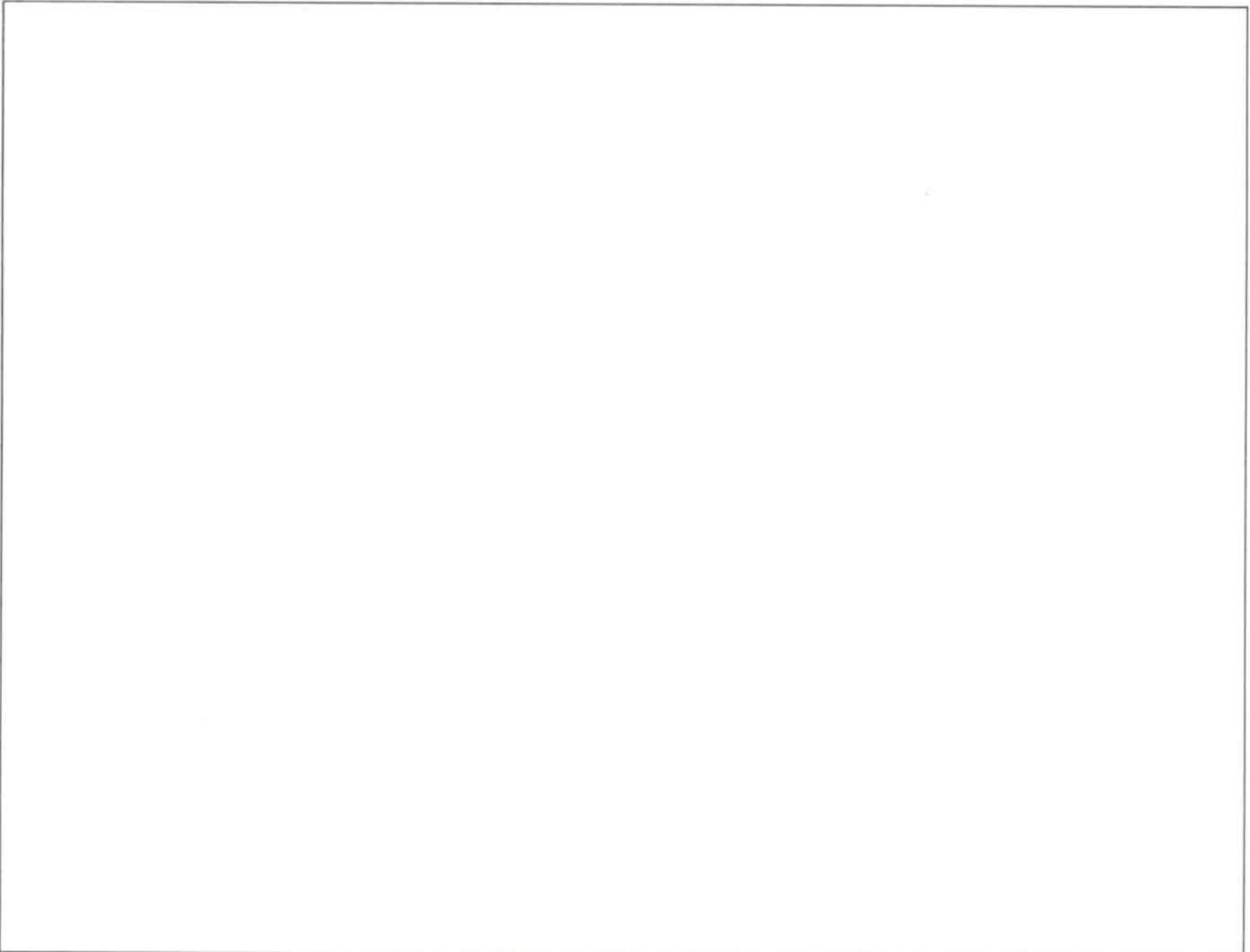

Item	Description	Source	Remarks
SN-11 ที่แขวนกระดาษชำระ	MODEL: AS SHOWN COLOUR/FINISH: CHROME SIZE: AS SHOWN		อุปกรณ์ของเดิม

Instructions:

1. All quantities to be verified by manufacturer/ installer.
2. Manufacturer to provide prototype of sanitary wares/ fittings and accessories for LIDG 's designer approval prior to production
3. To be international wired for use in Local context.
4. Manufacturer to supply all necessary hardware and instruction for installation of fixture.
5. Manufacturer to co-ordinate all wiring requirements for permanent surface mounting and provide hanging / security details for electrician.
6. Manufacturer warrants all products from all defects and guarantees to replace any or all parts should they prove deficient within one year from date of owner acceptance. All costs in this regard shall be borne by the manufacturer.
7. All supplied items to be contract quality ,suitable for commercial use.

Project :	โรงพยาบาล ศิริราช ปิยมหาราชการุณย์ ชั้น 15 โซน B	Date :	ISSUED 02 มีนาคม 2563
------------------	---	---------------	---------------------------------

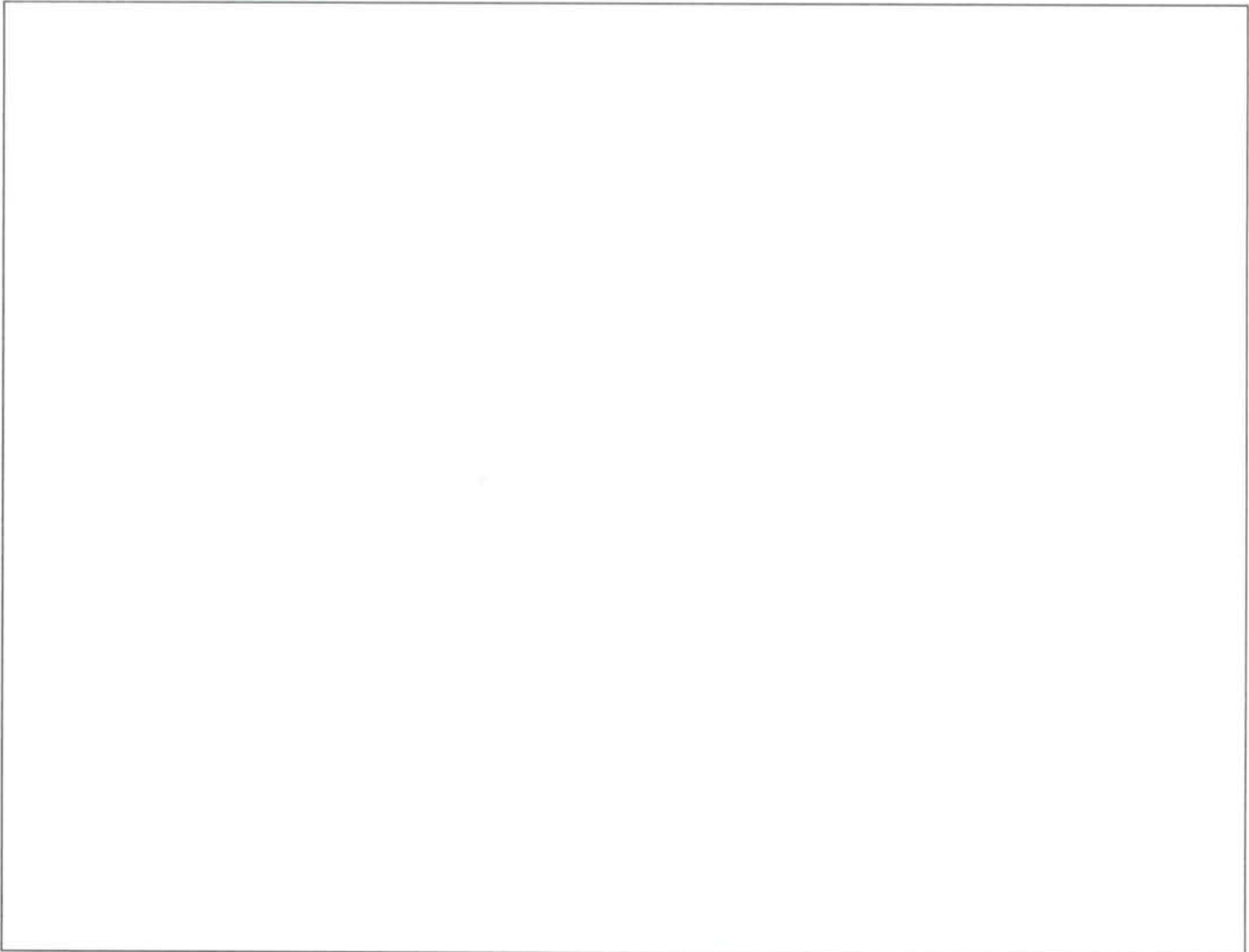

Item	Description	Source	Remarks
SN-12 ชุดฝักบัวอาบน้ำแบบ ก้านปรับระดับ	MODEL: AS SHOWN COLOUR/FINISH: CHROME SIZE: AS SHOWN		อุปกรณ์ของเดิม

- Instructions:
1. All quantities to be verified by manufacturer/ installer.
 2. Manufacturer to provide prototype of sanitary wares/fittings and accessories for LIDG 's designer approval prior to production
 3. To be international wired for use in Local context.
 4. Manufacturer to supply all necessary hardware and instruction for installation of fixture.
 5. Manufacturer to co-ordinate all wiring requirements for permanent surface mounting and provide hanging / security details for electrician.
 6. Manufacturer warrants all products from all defects and guarantees to replace any or all parts should they prove deficient within one year from date of owner acceptance. All costs in this regard shall be borne by the manufacturer.
 7. All supplied items to be contract quality ,suitable for commercial use.

Project :	โรงพยาบาล ศิริราช ปิยมหาราชการุณย์ ชั้น 15 โซน B	Date :	ISSUED 02 มีนาคม 2563
------------------	---	---------------	--------------------------

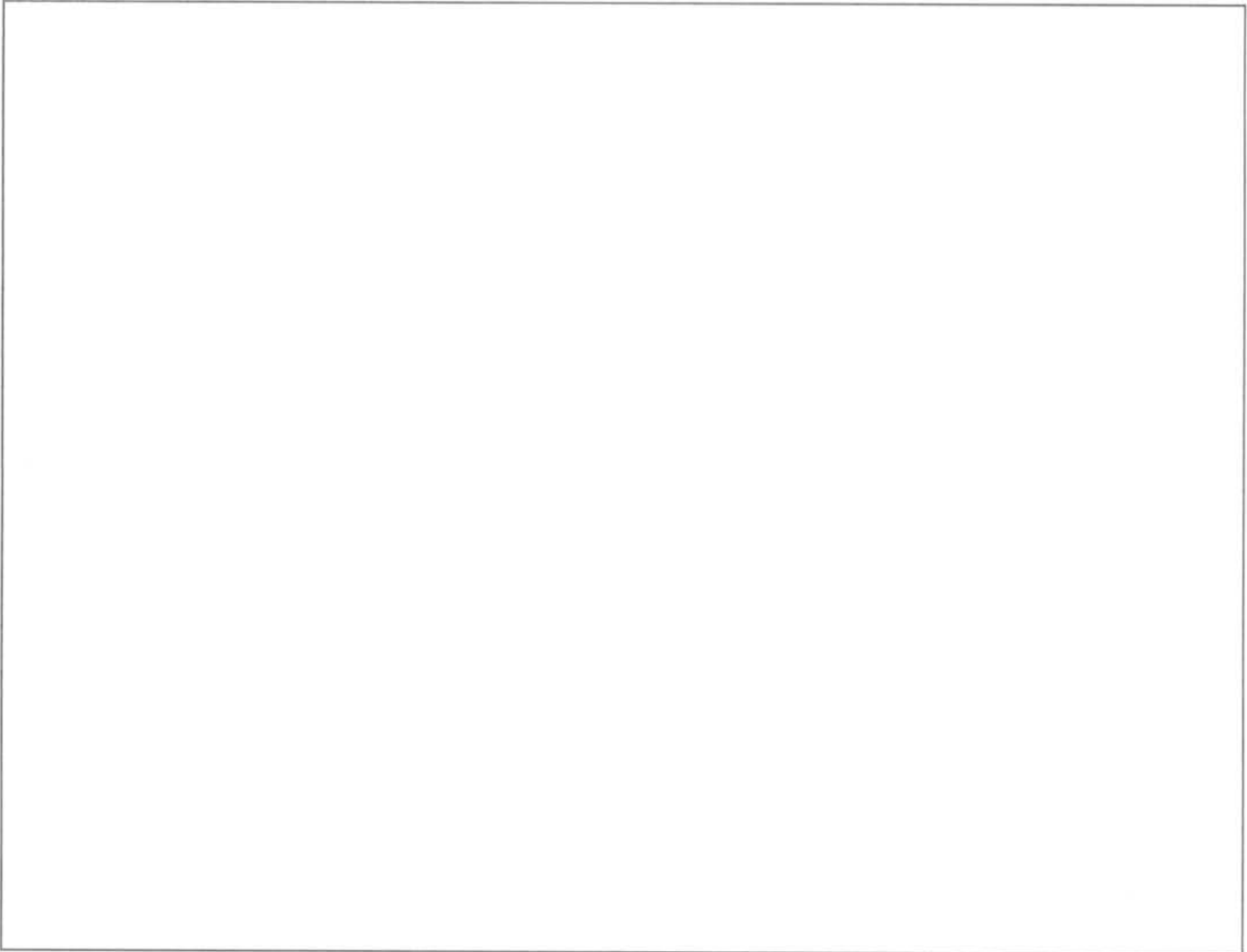

Item	Description	Source	Remarks
SN-13 ชุดสายฉีดชำระ	MODEL: AS SHOWN COLOUR/FINISH: CHROME SIZE: AS SHOWN		อุปกรณ์ของเดิม

Instructions:

1. All quantities to be verified by manufacturer/ installer.
2. Manufacturer to provide prototype of sanitary wares/fittings and accessories for LIDG 's designer approval prior to production
3. To be international wired for use in Local context.
4. Manufacturer to supply all necessary hardware and instruction for installation of fixture.
5. Manufacturer to co-ordinate all wiring requirements for permanent surface mounting and provide hanging / security details for electrician.
6. Manufacturer warrants all products from all defects and guarantees to replace any or all parts should they prove deficient within one year from date of owner acceptance. All costs in this regard shall be borne by the manufacturer.
7. All supplied items to be contract quality ,suitable for commercial use.

Project :	โรงพยาบาล ศิริราช ปิยมหาราชการุณย์ ชั้น 15 โซน B	Date :	ISSUED 02 มีนาคม 2563
------------------	---	---------------	---------------------------------

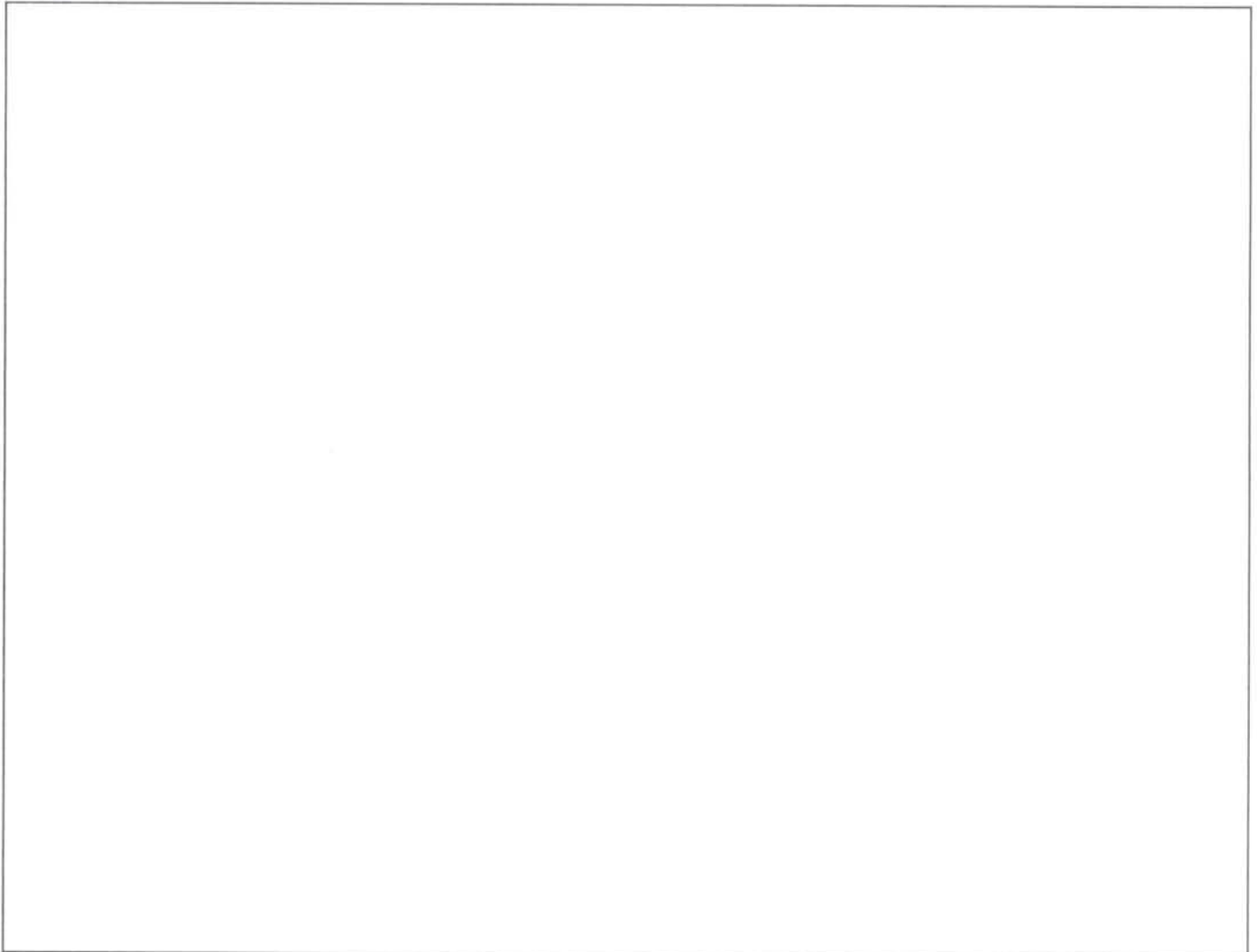

Item	Description	Source	Remarks
SN-14 ที่วางสุขุ	MODEL: AS SHOWN COLOUR/FINISH: CHROME SIZE: AS SHOWN		อุปกรณ์ของเดิม

Instructions:

1. All quantities to be verified by manufacturer/ installer.
2. Manufacturer to provide prototype of sanitary wares/fittings and accessories for LIDG 's designer approval prior to production
3. To be international wired for use in Local context.
4. Manufacturer to supply all necessary hardware and instruction for installation of fixture.
5. Manufacturer to co-ordinate all wiring requirements for permanent surface mounting and provide hanging / security details for electrician.
6. Manufacturer warrants all products from all defects and guarantees to replace any or all parts should they prove deficient within one year from date of owner acceptance. All costs in this regard shall be borne by the manufacturer.
7. All supplied items to be contract quality ,suitable for commercial use.

Project :	โรงพยาบาล ศิริราช ปิยมหาราชการุณย์ ชั้น 15 โซน B	Date :	ISSUED 02 มีนาคม 2563
------------------	--	---------------	---------------------------------

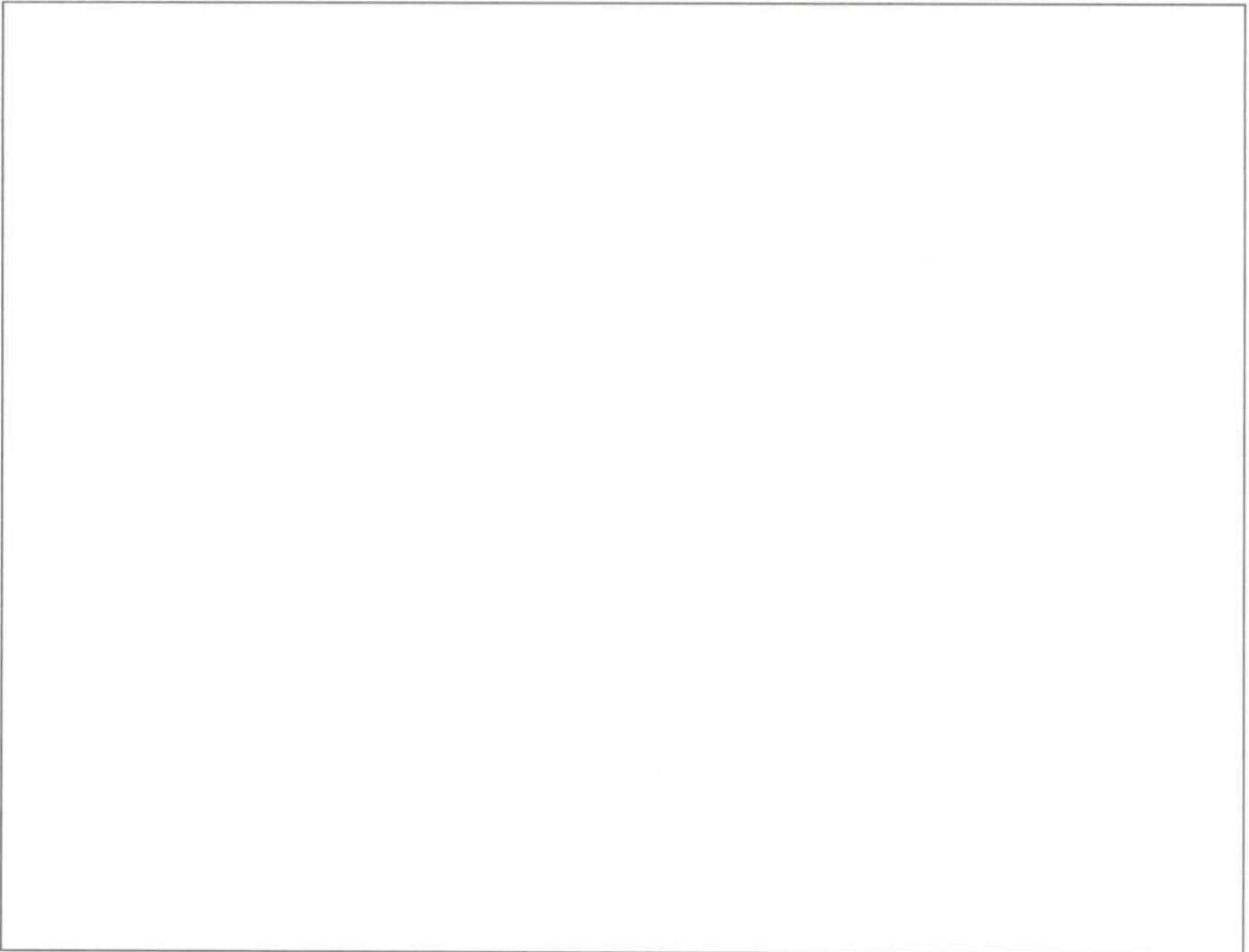

Item	Description	Source	Remarks
SN-15 โถสุขภัณฑ์แบบมี หม้อน้ำ	MODEL: AS SHOWN COLOUR/FINISH: CHROME SIZE: AS SHOWN		อุปกรณ์ของเดิม

Instructions:

1. All quantities to be verified by manufacturer/ installer.
2. Manufacturer to provide prototype of sanitary wares/fittings and accessories for LIDG 's designer approval prior to production
3. To be international wired for use in Local context.
4. Manufacturer to supply all necessary hardware and instruction for installation of fixture.
5. Manufacturer to co-ordinate all wiring requirements for permanent surface mounting and provide hanging / security details for electrician.
6. Manufacturer warrants all products from all defects and guarantees to replace any or all parts should they prove deficient within one year from date of owner acceptance. All costs in this regard shall be borne by the manufacturer.
7. All supplied items to be contract quality ,suitable for commercial use.

Project :	โรงพยาบาล ศิริราช ปิยมหาราชการุณย์ ชั้น 15 โซน B	Date :	ISSUED 02 มีนาคม 2563
------------------	---	---------------	---------------------------------

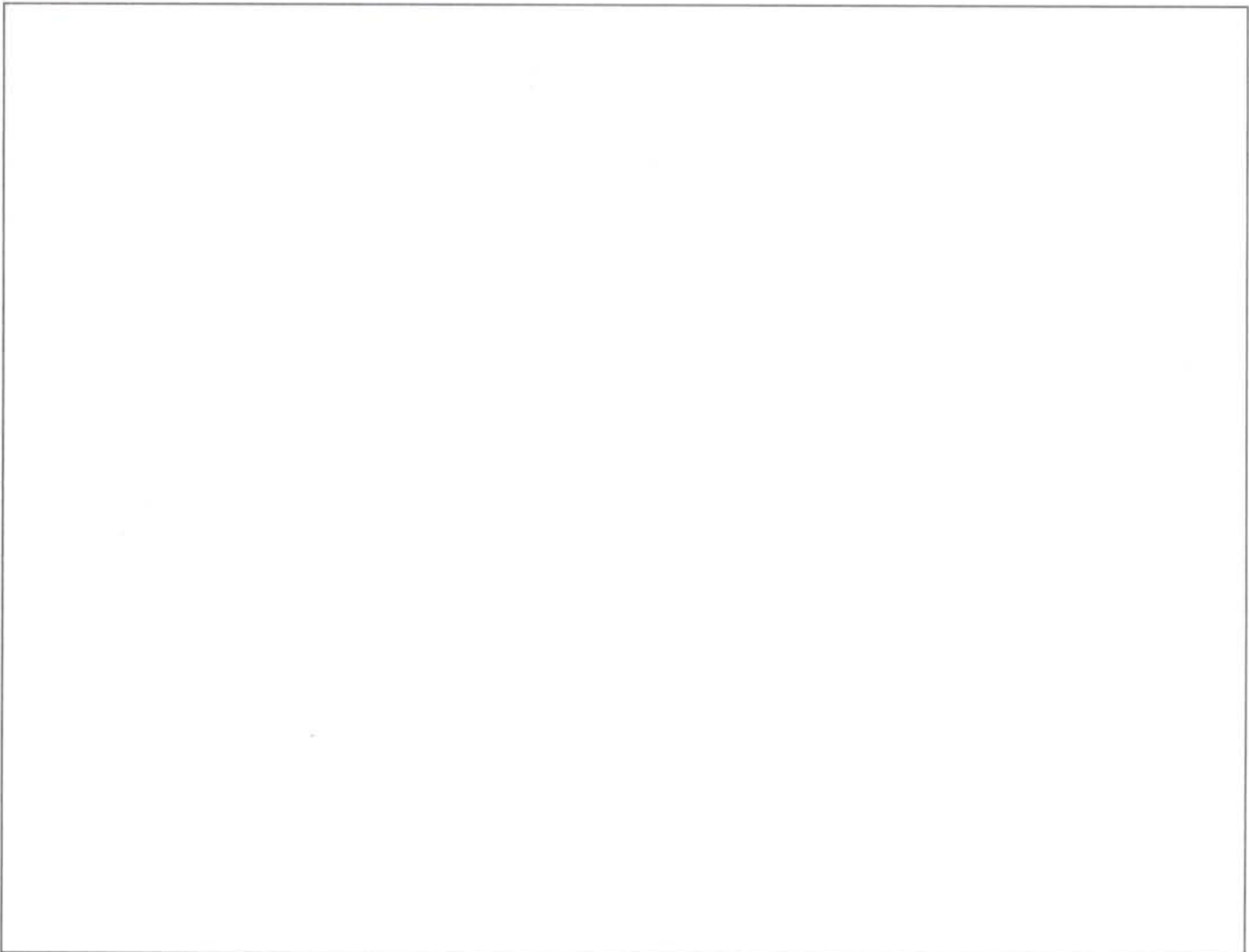

Item	Description	Source	Remarks
SN-16 ชุดสายฉีดชำระ	MODEL: AS SHOWN COLOUR/FINISH: CHROME SIZE: AS SHOWN		อุปกรณ์ของเดิม

- Instructions:**
1. All quantities to be verified by manufacturer/ installer.
 2. Manufacturer to provide prototype of sanitary wares/fittings and accessories for LIDG 's designer approval prior to production
 3. To be international wired for use in Local context.
 4. Manufacturer to supply all necessary hardware and instruction for installation of fixture.
 5. Manufacturer to co-ordinate all wiring requirements for permanent surface mounting and provide hanging / security details for electrician.
 6. Manufacturer warrants all products from all defects and guarantees to replace any or all parts should they prove deficient within one year from date of owner acceptance. All costs in this regard shall be borne by the manufacturer.
 7. All supplied items to be contract quality ,suitable for commercial use.

Project :	โรงพยาบาล ศิริราช ปิยมหาราชการุณย์ ชั้น 15 โซน B	Date :	ISSUED 02 มีนาคม 2563
------------------	---	---------------	---------------------------------

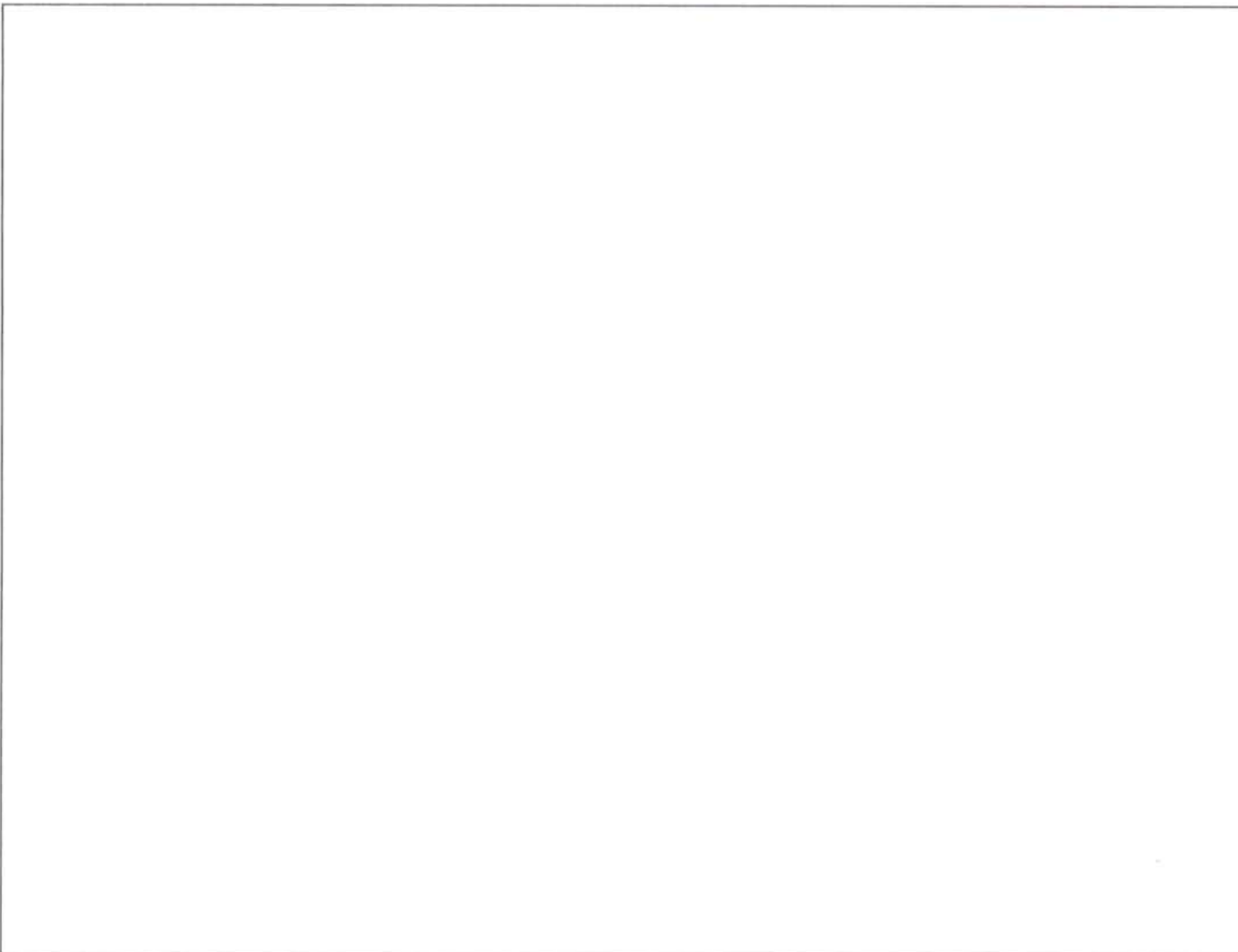

Item	Description	Source	Remarks
SN-17 ฝาท่อน้ำทิ้ง	MODEL: AS SHOWN COLOUR/FINISH: CHROME SIZE: AS SHOWN		อุปกรณ์ของเดิม

- Instructions:
1. All quantities to be verified by manufacturer/ installer.
 2. Manufacturer to provide prototype of sanitary wares/fittings and accessories for LIDG 's designer approval prior to production
 3. To be international wired for use in Local context.
 4. Manufacturer to supply all necessary hardware and instruction for installation of fixture.
 5. Manufacturer to co-ordinate all wiring requirements for permanent surface mounting and provide hanging / security details for electrician.
 6. Manufacturer warrants all products from all defects and guarantees to replace any or all parts should they prove deficient within one year from date of owner acceptance. All costs in this regard shall be borne by the manufacturer.
 7. All supplied items to be contract quality ,suitable for commercial use.

Project :	โรงพยาบาล ศิริราช ปิยมหาราชการุณย์ ชั้น 15 โซน B	Date :	ISSUED 02 มีนาคม 2563
------------------	--	---------------	---------------------------------

หมายเหตุ: เช็คนขนาดและพื้นที่หน้างานก่อนการติดตั้งทุกครั้ง

Item	Description	Source	Remarks
MR-01 บานกระจกห้องน้ำ	MODEL: AS SHOWN COLOUR/FINISH: CHROME SIZE: AS SHOWN		TO BID

- Instructions:**
- All quantities to be verified by manufacturer/ installer.
 - Manufacturer to provide prototype of sanitary wares/ fittings and accessories for LIDG 's designer approval prior to production
 - To be international wired for use in Local context.
 - Manufacturer to supply all necessary hardware and instruction for installation of fixture.
 - Manufacturer to co-ordinate all wiring requirements for permanent surface mounting and provide hanging / security details for electrician.
 - Manufacturer warrants all products from all defects and guarantees to replace any or all parts should they prove deficient within one year from date of owner acceptance. All costs in this regard shall be borne by the manufacturer.
 - All supplied items to be contract quality ,suitable for commercial use.

โรงพยาบาล ศิริราชปิยมหาราชการุณย์

ชั้น 15 โซน B

- 2.0 ข้อกำหนดสำหรับเฟอร์นิเจอร์ และของตกแต่ง จำพวกติดผนังหรือเคลื่อนย้ายไม่ได้
- 2.3 ข้อกำหนด งานประตุนหน้าต่าง

ISSUED DATE

02 มีนาคม 2563

INTERIOR ARCHITECTURE
DESIGNER

LEOINTER

Leo International Design Group Co., Ltd.
39th Floor, Ocean Tower 2
75/108-109 Sukhumvit 19 Road
Klongtoey Nua, Vadhana, Bangkok 10110,
Thailand

Tel : +66 (0) 2261 7733

Fax : +66 (0) 2261 7734

E-mail : lldg@lldg.co.th

www.lldg.co.th

Project :	โรงพยาบาล ศิริราช ปิยมหาราชการุณย์ ชั้น 15 โซน B	Date :	ISSUED 02 มีนาคม 2563
------------------	--	---------------	---------------------------------

มาตรฐานการกำหนดข้อมูล

หน้าสารบัญ

ก. ข้อกำหนดทั่วไป

(ตามข้อกำหนดมาตรฐานของบริษัท ลีโล อินเตอร์เน็ทชั่นแนล กรุ๊ป)

ข. ข้อกำหนด เฟอร์นิเจอร์ลอยตัว เฟอร์นิเจอร์ติดผนัง และอุปกรณ์ต่าง ๆ

1.0 วัสดุและข้อกำหนดต่าง ๆ

- 1.1 ข้อกำหนด ฝ้าเพดาน
- 1.2 ข้อกำหนด พรม
- 1.3 ข้อกำหนด กระຈก
- 1.4 ข้อกำหนด ลามิเนต
- 1.5 ข้อกำหนด โลหะต่างๆ
- 1.6 ข้อกำหนด สีทาต่างๆ
- 1.7 ข้อกำหนด หินอ่อน / กระเบื้องเซรามิก / กระเบื้องโมเสค
- 1.8 ข้อกำหนด วอลเปเปอร์ / ฝ้าและผนังบุผนัง
- 1.9 ข้อกำหนด ไม้เนื้อแข็ง / ไม้จริง
- 1.10 ข้อกำหนด วัสดุและอุปกรณ์อื่นๆ
- 1.11 ข้อกำหนด กระเบื้องยาง

2.0 ข้อกำหนดสำหรับเฟอร์นิเจอร์ และของตกแต่ง จำพวกติดผนัง หรือเคลื่อนย้ายไม่ได้

- 2.1 ข้อกำหนด งานระบบติดตั้งไฟฟ้า
- 2.2 ข้อกำหนด งานสุขาภิบาล
- 2.3 ข้อกำหนด งานประตูหน้าต่าง
- 2.4 ข้อกำหนด งานจัดแสงทั่วไป

3.0 รพ.ศิริราช ปิยมหาราชการุณย์, กรุงเทพฯ, ประเทศไทย

- 3.1 ข้อกำหนด เฟอร์นิเจอร์ลอยตัว
- 3.2 ข้อกำหนด โคมไฟตกแต่ง
- 3.3 ข้อกำหนด ฝ้า, สิ่งทอ
- 3.4 ข้อกำหนด พรม
- 3.5 ข้อกำหนด ภาพศิลปะ, ของตกแต่ง

2.0 ข้อกำหนดสำหรับเฟอร์นิเจอร์ และของตกแต่ง

จำพวกติดผนัง หรือเคลื่อนย้ายไม่ได้

สำหรับ

โรงพยาบาล ศิริราช ปิยมหาราชการุณย์

นำเสนอวัสดุในการตกแต่งภายใน

อาคาร ปิยมหาราชการุณย์ ชั้น 15 โซน B

Project :

โรงพยาบาล ศิริราช ปิยมหาราชการุณย์
ชั้น 15 โซน B

Date :

ISSUED

02 มีนาคม 2563

FIXED GOODS SPECIFICATION DATA SHEET

2.3 DOOR / IRONMONGERY SPECIFICATION

CODE	CONTENTS	PAGE
IR-01	D-01 ชุดประตูบานเดี่ยวชนิดกันไฟพร้อมอุปกรณ์ @ WARD ROOM	2.3-01
IR-02	D-01A ชุดอุปกรณ์ประตูห้องพักรักษาตัว @ WARD ROOM	2.3-02
IR-03	D-02 ประตูบานเลื่อนเปิดลามีเนตพร้อมอุปกรณ์ @ TOILET ROOM	2.3-03
IR-04	D-03 ประตูบานเลื่อนกระจก 2 ตอน @ BARTH ROOM	2.3-04
IR-05	อุปกรณ์บานยึดที่วีดีดผนัง [เทียบเท่าของเดิม]	2.3-05
IR-06	CONCEAL HINGES	2.3-06
IR-07	DRAWER RUNNER	2.3-07

2.3 ข้อกำหนดสำหรับงานประตู

สำหรับ

โรงพยาบาล ศิริราช ปิยมหาราชการุณย์

นำเสนอวัสดุในการตกแต่งภายใน

อาคาร ปิยมหาราชการุณย์ ชั้น 15 โซน B

Project :	โรงพยาบาล ศิริราช ปิยมหาราชการุณย์ ชั้น 15 โซน B	Date :	ISSUED 02 มีนาคม 2563
------------------	--	---------------	---------------------------------

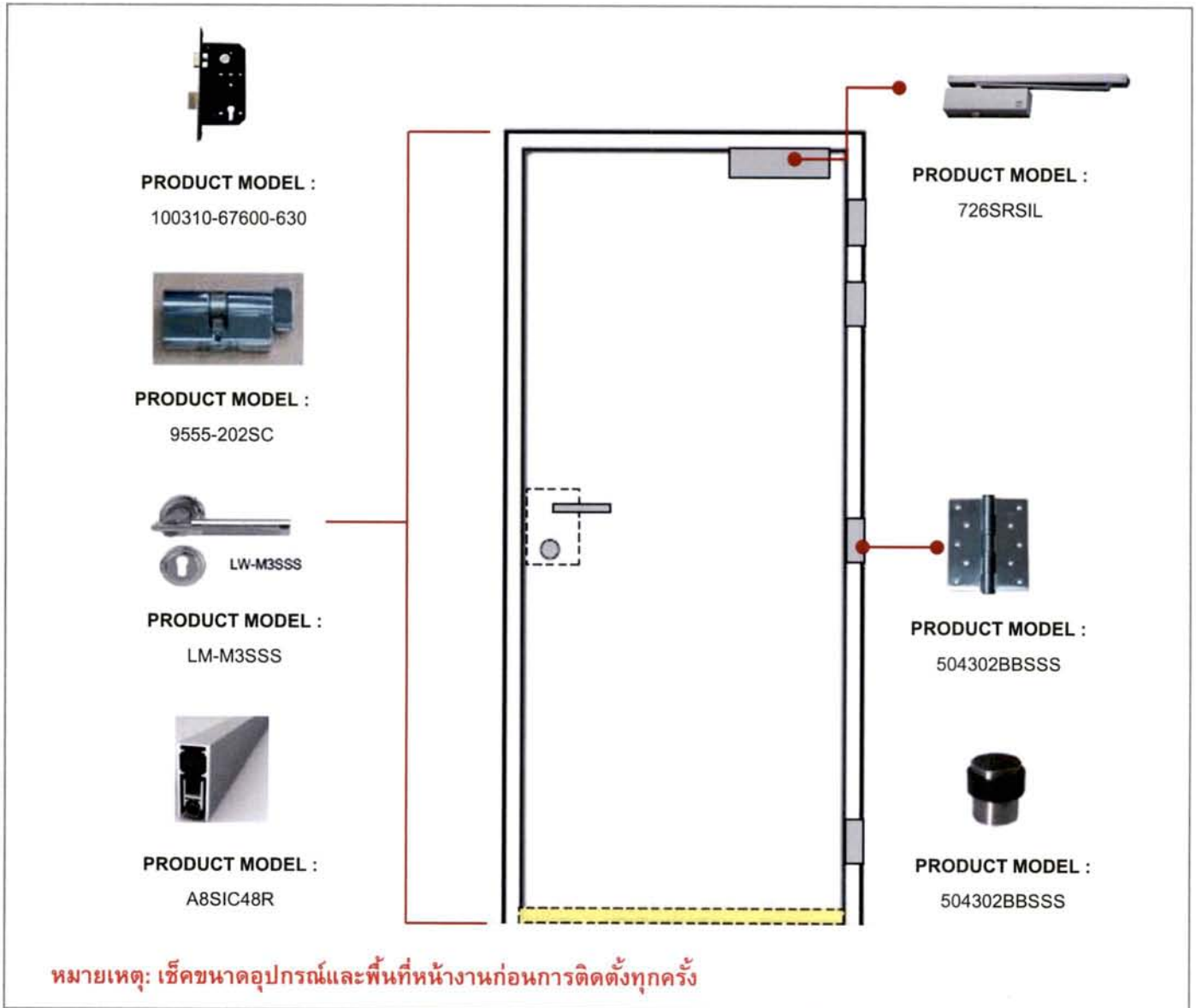

Item	Description	Source	Remarks
D-01 ชุดประตูบานเดี่ยวชนิด กันไฟพร้อมอุปกรณ์ @WARD ROOM	MODEL: AS SPECIFIED COLOUR/FINISH: SATIN STAINLESS SIZE: AS SPECIFIED	ASSA ABLOY (Thailand) Limited 1919 Preecha Group Building 5th . Floor Pattanakarn Road. Suanluang, Suanluang, Bangkok 10250 CONTACT: K.SUKITNUT MOBILE: 092-225-4919 TEL: 02-722-7371 FAX: 02-722-7375 upto 76 EMAIL: sukitnut.satapanstien@assaabloy.com	

Instructions:

- All quantities to be verified by manufacturer/ installer.
- Manufacturer to provide finish samples and exact prototype for LIDG designer approval prior to fabrication.
- Manufacturer to supply all necessary hardware and instruction for installation of fixture.
- Manufacturer warrants all products from all defects and guarantees to replace any or all parts should they prove deficient within one year from date of owner acceptance. All costs in this regard shall be borne by the manufacturer.
- All supplied items to be contract quality ,suitable for commercial use.

Project :	โรงพยาบาล ศิริราช ปิยมหาราชการุณย์ ชั้น 15 โซน B	Date :	ISSUED 02 มีนาคม 2563
------------------	--	---------------	---------------------------------



PRODUCT MODEL :
100310-67600-630



PRODUCT MODEL :
9555-202SC

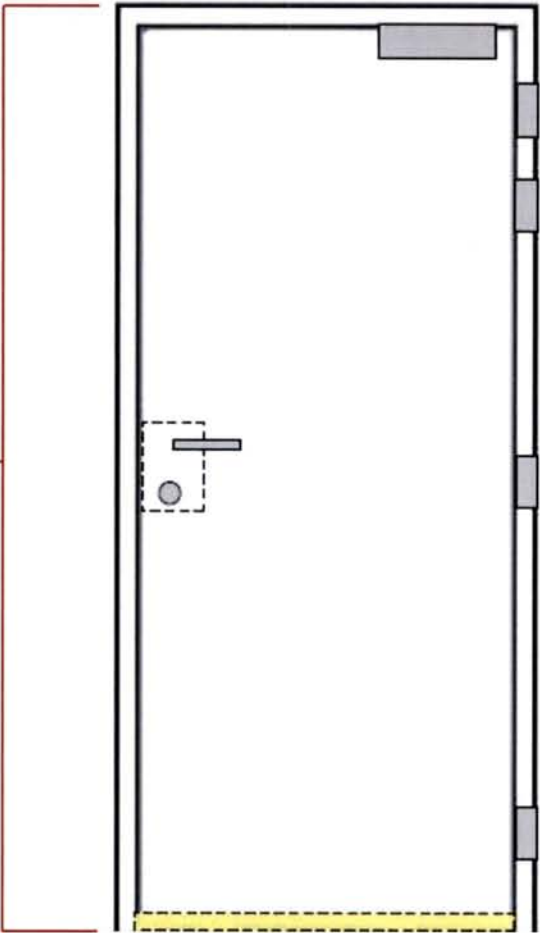

หมายเหตุ: เช็คนขนาดอุปกรณ์และพื้นที่หน้างานก่อนการติดตั้งทุกครั้ง

Item	Description	Source	Remarks
D-01A ชุดอุปกรณ์ ประตูห้องพักรับผู้ป่วย @ WARD ROOM	MODEL: AS SPECIFIED COLOUR/FINISH: SATIN STAINLESS SIZE: AS SPECIFIED	ASSA ABLOY (Thailand) Limited 1919 Preecha Group Building 5th . Floor Pattanakarn Road. Suanluang, Suanluang, Bangkok 10250 CONTACT: K.SUKITNUT MOBILE: 092-225-4919 TEL: 02-722-7371 FAX: 02-722-7375 upto 76 EMAIL: sukitnut.satapanstien@assaabloy.com	ประตูห้องพักรับ ผู้ป่วย บ้านเดิม

Instructions:

1. All quantities to be verified by manufacturer/ installer.
2. Manufacturer to provide finish samples and exact prototype for LIDG designer approval prior to fabrication.
3. Manufacturer to supply all necessary hardware and instruction for installation of fixture.
4. Manufacturer warrants all products from all defects and guarantees to replace any or all parts should they prove deficient within one year from date of owner acceptance. All costs in this regard shall be borne by the manufacturer.
5. All supplied items to be contract quality ,suitable for commercial use.

Project :	โรงพยาบาล ศิริราช ปิยมหาราชการุณย์ ชั้น 15 โซน B	Date :	ISSUED 02 มีนาคม 2563
------------------	--	---------------	---------------------------------

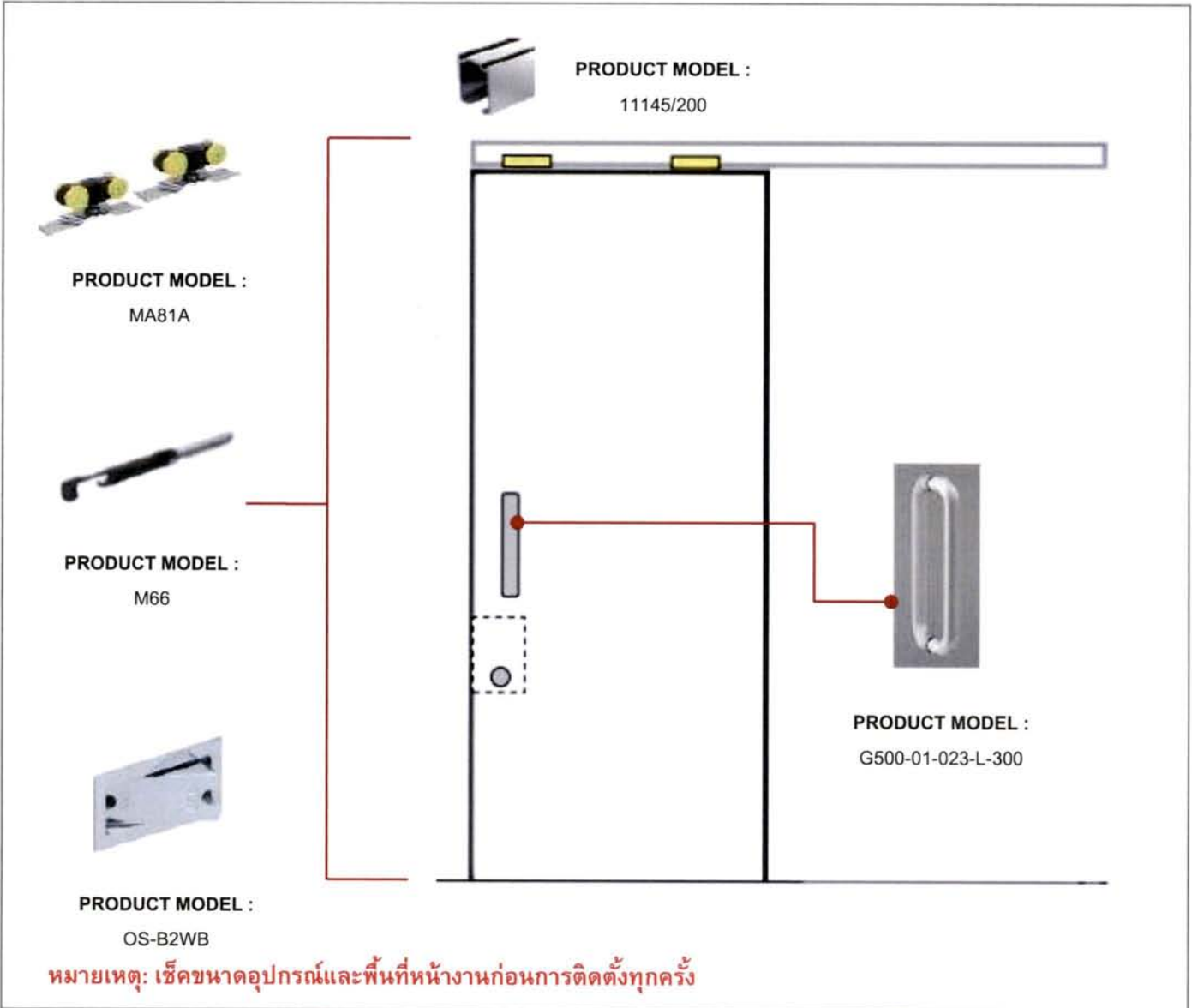

Item	Description	Source	Remarks
D-02 ประตูบานเลื่อนปิด ลามิเนตพร้อมอุปกรณ์ TOILET @WARD ROOM	MODEL: AS SPECIFIED COLOUR/FINISH: SATIN STAINLESS SIZE: AS SPECIFIED	TODAY STYLE 2100 Co.,Ltd. 1839 ONNUT RD. ONNUT,SUANLUANG,BANGKOK 10250 CONTACT : K.MANA MOBILE: 081-734-3441 TEL: 02-231-4232 FAX: 02-721-3389 EMAIL: info@todatstyle2001.com	

Instructions:

- All quantities to be verified by manufacturer/ installer.
- Manufacturer to provide finish samples and exact prototype for LIDG designer approval prior to fabrication.
- Manufacturer to supply all necessary hardware and instruction for installation of fixture.
- Manufacturer warrants all products from all defects and guarantees to replace any or all parts should they prove deficient within one year from date of owner acceptance. All costs in this regard shall be borne by the manufacturer.
- All supplied items to be contract quality ,suitable for commercial use.

Project :	โรงพยาบาล ศิริราช ปิยมหาราชการุณย์ ชั้น 15 โซน B	Date :	ISSUED 02 มีนาคม 2563
------------------	--	---------------	---------------------------------



- * **CUSTOM** Available on 10 mm. tempered glass
- * 304 stainless steel refined polishing slide rail, strong bearing capacity and anti-rust performance.
- * Organ type sealing rubber, great waterproof effect



หมายเหตุ: เช็คนขนาดอุปกรณ์และพื้นที่หน้างานก่อนการติดตั้งทุกครั้ง

Item	Description	Source	Remarks
D-03 ประตูบานเลื่อนกระจก 2 ตอน BARTH ROOM	MODEL: AS SPECIFIED COLOUR/FINISH: SATIN STAINLESS SIZE: AS SPECIFIED	SETHAPAT(1990).CO.,LTD 15 chan 43 yak 33, tuengwatdon, sathorn, bangkok, Thailand 10120 CONTACT : K.THREENATHAPATT MOBILE: 062-952-9896 TEL: 02-674-8043-4 EMAIL: luprasongchit.t@gmail.com	

Instructions:

1. All quantities to be verified by manufacturer/ installer.
2. Manufacturer to provide finish samples and exact prototype for LIDG designer approval prior to fabrication.
3. Manufacturer to supply all necessary hardware and instruction for installation of fixture.
4. Manufacturer warrants all products from all defects and guarantees to replace any or all parts should they prove deficient within one year from date of owner acceptance. All costs in this regard shall be borne by the manufacturer.
5. All supplied items to be contract quality ,suitable for commercial use.

Project :	โรงพยาบาล ศิริราช ปิยมหาราชการุณย์ ชั้น 15 โซน B	Date :	ISSUED 02 มีนาคม 2563
------------------	--	---------------	---------------------------------



SKU

456588004_TH-842770486

รุ่น

402-402

- ชุดขาแขวนทีวีรุ่นยอดนิยม สามารถติดตั้งง่ายได้ด้วยตัวเอง แข็งแรงทนทาน และคุ้มค่า
- ผลิตจากเหล็กอย่างหนา เหมาะสำหรับแขวนทีวี LED/ LCD ขนาด 26"~55"
- รับน้ำหนักทีวี ได้ถึง 50kg
- ฐานเหล็กที่ยึดกับผนัง ขนาดประมาณ 18cm x 28cm / ส่วนแผ่นที่รองรับยึดติดกับหลังทีวี มีขนาด 19cm x 46cm
- สามารถหมุนหันซ้าย-ขวา ได้ 120 องศา และ ก้ม-เงย ได้ 15 องศา
- สามารถยืดออกมาสุดได้ประมาณ (arm stretch) 40-45ซม.
- VESA Mounting Interface Standard (MIS) (คือ ระยะห่างของรูยึดหลังทีวี 4 รู ที่สามารถใช้รุ่นนี้ได้): 50x50mm, 75x75mm, 100x100mm, 200x100mm, 200x200mm, 400x200mm, 400x300mm, 300x300mm, หรือ 400x400 mm.
- รุ่นนี้เป็นแบบ 2 แขน ซึ่งจะช่วยให้ยึดกับผนังและตัวทีวี ได้แข็งแรงดีมาก
- ชุดขาแขวนทีวี สำหรับทีวีขนาด 26" - 55" ปรับหันซ้าย-ขวา และก้ม-เงยได้

Item	Description	Source	Remarks
IR-05 แป้นยึดทีวี แบบติดผนัง	MODEL: AS SPECIFIED COLOUR/FINISH: SATIN STAINLESS SIZE: AS SPECIFIED		TO BID

Instructions:

1. All quantities to be verified by manufacturer/ installer.
2. Manufacturer to provide finish samples and exact prototype for LIDG designer approval prior to fabrication.
3. Manufacturer to supply all necessary hardware and instruction for installation of fixture.
4. Manufacturer warrants all products from all defects and guarantees to replace any or all parts should they prove deficient within one year from date of owner acceptance. All costs in this regard shall be borne by the manufacturer.
5. All supplied items to be contract quality ,suitable for commercial use.

Project :	โรงพยาบาล ศิริราช ปิยมหาราชการุณย์ ชั้น 15 โซน B	Date :	ISSUED 02 มีนาคม 2563
------------------	--	---------------	---------------------------------

บานพับถ้วย DUOMATIC PREMIUM มุมเปิด 110°

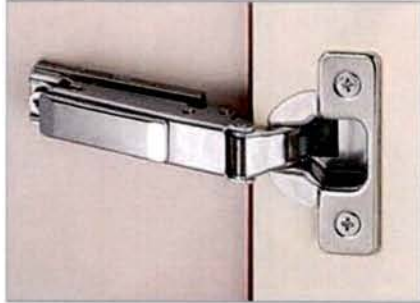

ฐานรองบานพับถ้วย



329.80.528
329.80.546
329.80.555

เป็นบานพับเกรดสูง รูปแบบบานพับพร้อมอุปกรณ์ปิดนุ่มนวลภายใน
ถ้วยบานพับ อุปกรณ์ปิดนุ่มนวลนี้จะไม่สามารถมองเห็นได้หลังจากติดตั้ง
เรียบร้อยแล้ว กรุณาเจาะความลึกของถ้วยบานพับให้ได้ 13.5 มม.

ติดตั้งแบบทับขอบ

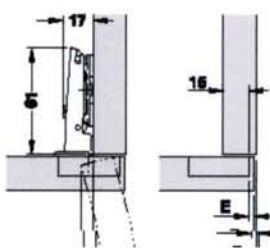

329.17.700

ติดตั้งแบบกลางขอบ/ขารองแบบคู่

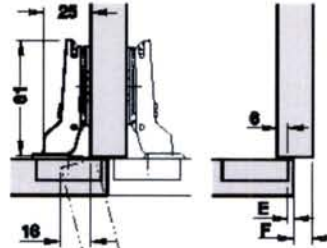

329.17.702

ติดตั้งแบบในขอบ

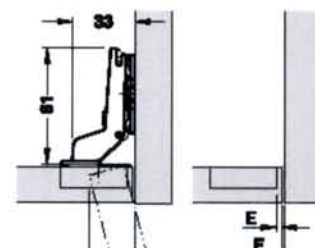

329.17.703

หมายเหตุ: เช็ขนาดอุปกรณ์และพื้นที่หน้างานก่อนการติดตั้งทุกครั้ง

Item	Description	Source	Remarks
IR-09 CONCEAL HINGES	MODEL: AS SPECIFIED COLOUR/FINISH: SATIN STAINLESS SIZE: AS SPECIFIED	HAFELE THAILAND LIMITED 57 Soi Sukhumvit 64 Sukhumvit Road, Bangchak , Phrakanong , Bangkok 10260 (THAILAND) CONTACT : K.SAINAMPHUNG MOBILE : 085-111-9277 TEL : 0-274 -17171#417 FAX : 0-274-17272 EMAIL: sainamphueng@hafele.co.th	

Instructions:

- All quantities to be verified by manufacturer/ installer.
- Manufacturer to provide finish samples and exact prototype for LIDG designer approval prior to fabrication.
- Manufacturer to supply all necessary hardware and instruction for installation of fixture.
- Manufacturer warrants all products from all defects and guarantees to replace any or all parts should they prove deficient within one year from date of owner acceptance. All costs in this regard shall be borne by the manufacturer.
- All supplied items to be contract quality ,suitable for commercial use.

Project :

โรงพยาบาล ศิริราช ปิยมหาราชการุณย์
ชั้น 15 โซน B

Date :

ISSUED

02 มีนาคม 2563

L=R

STAINLESS
304
STEEL

5302S

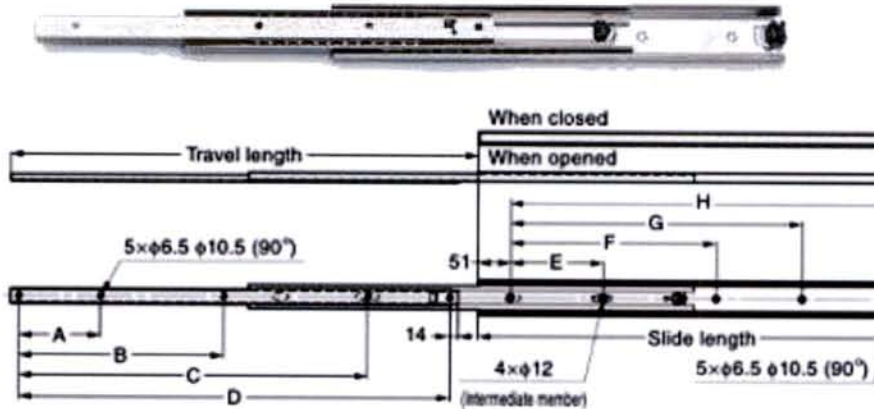

Cut Out Dimensions

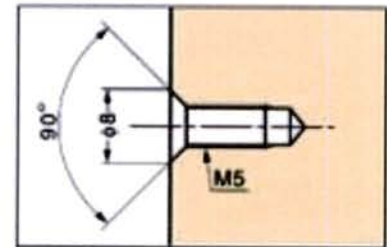

Item Code	Item Name	Slide Length	Travel Length
190-112-730	5302S-300	300	334
190-112-731	5302S-350	350	384
190-112-732	5302S-400	400	433
190-112-733	5302S-450	450	482
190-112-734	5302S-500	500	532
190-112-735	5302S-550	550	580

หมายเหตุ: เช็ขนาดอุปกรณ์และพื้นที่หน้างานก่อนการติดตั้งทุกครั้ง

Item	Description	Source	Remarks
IR-10 DRAWER RUNNER @ALL AREA	MODEL: AS SPECIFIED COLOUR/FINISH: SATIN STAINLESS SIZE: AS SPECIFIED	TODAY STYLE 2100 Co.,Ltd. 1839 ONNUT RD. ONNUT,SUANLUANG,BANGKOK 10250 CONTACT : K.MANA MOBILE: 081-734-3441 TEL:02-231-4232 FAX:02-721-3389 EMAIL: info@todaystyle2001.com	

Instructions:

- All quantities to be verified by manufacturer/ installer.
- Manufacturer to provide finish samples and exact prototype for LIDG designer approval prior to fabrication.
- Manufacturer to supply all necessary hardware and instruction for installation of fixture.
- Manufacturer warrants all products from all defects and guarantees to replace any or all parts should they prove deficient within one year from date of owner acceptance. All costs in this regard shall be borne by the manufacturer.
- All supplied items to be contract quality ,suitable for commercial use.

3. LOOSE GOODS SPECIFICATION

รพ. ศิริราช ปิยมหาราชการุณย์ กรุงเทพมหานคร ประเทศไทย

PROPOSED INTERIOR FIT-OUT

FOR

15th. FLOOR WARD ROOM

3.1 LOOSE FURNITURE SPECIFICATION

รพ. ศิริราช ปิยมหาการุณย์ กรุงเทพฯ ประเทศไทย

PROPOSED INTERIOR FIT-OUT

FOR

15th. FLOOR WARD ROOM

INTERIOR ARCHITECTURE
DESIGNER

LEOINTER

39th Floor Ocean Tower II Building

75/108 -109 Sukhumvit 19 Road, Klongtoey Nua, Vadhana, Bangkok 10110, Thailand.

Tel : +66 (0) 2261 7733 Fax : +66 (0) 2261 7734 Email : lidg@lidg.co.th

Project :

รพ. ศิริราช ปิยมหาราชการุณย์ กรุงเทพฯ ประเทศไทย

15th. FLOOR WARD ROOM

Date :

ISSUED

2020 MAR 02

LOOSEGOODS SPECIFICATION DATA SHEET

CONTENTS

3.1 LOOSE FURNITURE SPECIFICATION

CASEGOOD

CAS-01	โต๊ะอาหารในห้องพักรักษาผู้ป่วย DINING TABLE AT WARD ROOM	3.1-01
CAS-02	โต๊ะข้างโซฟาในห้องพักรักษาผู้ป่วย SIDE TABLE AT WARD ROOM	3.1-02
CAS-03	ตู้ข้างเตียง ในห้องพักรักษาผู้ป่วย SIDE CABINET AT WARD ROOM	3.1-03

SEATING

SEA-01	เก้าอี้อาหารในห้องพักรักษาผู้ป่วย DINING TABLE AT WARD ROOM	3.1-01
SEA-02	โซฟาอนในห้องพักรักษาผู้ป่วย SOFA AT WARD ROOM	3.1-02
SEA-03	เก้าอี้นั่งแต่งตัวในห้องพักรักษาผู้ป่วย STOOL AT WARD ROOM	3.1-03

Project :	รพ. ศิริราช ปิยมหาราชการุณย์ กรุงเทพมหานคร ประเทศไทย 15th. FLOOR WARD ROOM	Date :	ISSUED 2020 MAR 02
------------------	--	---------------	------------------------------

H.750 MM.

18 MM.TOP ARTIFICIAL STONE
MODEL : MAE 003 SUPER
**RAINBOW ENTERPRISE
MARKETING GROUP CO.,LTD.**
[MASTER QUARTZ BY]
CONTACT : MANATCHANAN
TEL : +66 2 153 8687
FAX : +66 2 153 8687
MOBILE : +66 94 494 9907
E-MAIL : rmg.bkk@gmail.com

GREENLAM
SOLID WOOD LEG COLOUR
TO MATCH WOOD VENEER
AS PER SAMPLE
MODEL : SY2 5354
**GREENLAM ASIA PACIFIC
[THAILAND]CO.,LTD.**
CONTACT : KATTAREEYA
Tel : 02 294-2569
Fax : 02 294-2568
Mobile : 084 081-1422
E-mail : kattareeya.th@greenlam.com
www.greenlam.com

Item	โต๊ะอาหารในห้องพักรักษาตัว DINING TABLE AT WARD	Qty.	1 Nos./ RM.	Size	DIA.750H.750 MM.	Source	TO BID
-------------	--	-------------	----------------	-------------	------------------	---------------	--------

Instructions of 3.1 Loose Furniture Specification

Casegoods Furniture (Indoor)

- All wood to be kiln dried and treated to be insect and vermin free.
- All hinges, screws, bolts and other internal hardware to be resistant to corrosion.
- All wood finishes to be stained, full-filled, alcohol, water and burn resistant catalyzed or conversion lacquer finish.
- All exposed and internal wood surfaces to match specified finish.
- Provide heavy duty nylon glides at base/ legs.
- Drawer Slide: Provide full-extension heavy duty drawer slides.
- Construction for consoles, bedside tables, coffee tables, bed frames: Rails and frames to be double dowelled, screwed and glued. Veneer face plywood with solid edges for top / sides / back / drawer faces / door faces.
- Stones to be treated for alcohol and stain resistance where applicable.
- Provide heat and stain resistant finish to top of case goods.
- Ensure that piece will fit in lifts and through doors prior to commencing fabrication. Show all pieces in shop drawings.
- All materials used must be suitable for use in tropical and high humidity areas.
- 30cm.x30cm. finish samples to be provided by manufacturer for approval by LIDG's prior to production.
- 30cm.x30cm. wood and veneer stained finish samples to be submitted by manufacturer for LIDG's approval prior to production.
- Prototype to be provided by manufacturer for approval by LIDG's prior to production.
- All supplied items to be of contract quality, suitable for commercial use.
- Cabinet drawers & doors must be fitted properly aligned and must operate smoothly under various atmospheric conditions. Drawer side-mounted glides to be specified and painted.
- Any marble top must be 20mm. thick with polished edges on exposed sides and must have a tuff skin protective coating.
- All furniture must install non-corrosive, heavy duty, nylon carpet glides to fit the footprint of the leg.

Project :	รพ. ศิริราช ปิยมหาราชการุณย์ กรุงเทพมหานคร ประเทศไทย 15th. FLOOR WARD ROOM	Date :	ISSUED 2020 MAR 02
------------------	---	---------------	------------------------------

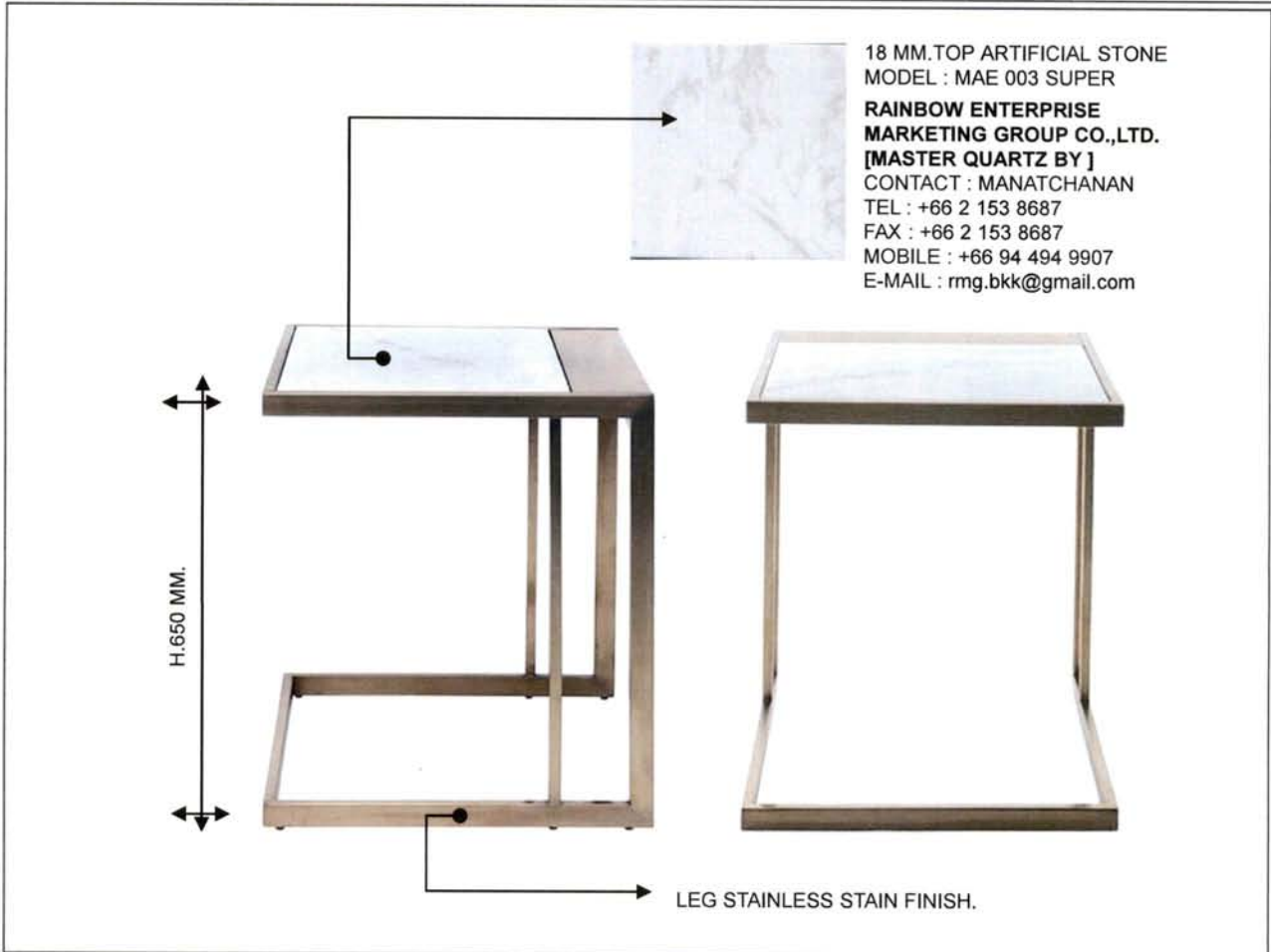

Item	โต๊ะข้างโซฟาในห้องพักรักษาผู้ป่วย	Qty.	1 Nos./ RM.	Size	W.500 XD.800 H.650 MM.	Source	TO BID
	SIDE TABLE AT WARD ROOM						

Instructions of 3.1 Loose Furniture Specification

Casegoods Furniture (Indoor)

- All wood to be kiln dried and treated to be insect and vermin free.
- All hinges, screws, bolts and other internal hardware to be resistant to corrosion.
- All wood finishes to be stained, full-filled, alcohol, water and burn resistant catalyzed or conversion lacquer finish.
- All exposed and internal wood surfaces to match specified finish.
- Provide heavy duty nylon glides at base/ legs.
- Drawer Slide: Provide full-extension heavy duty drawer slides.
- Construction for consoles, bedside tables, coffee tables, bed frames: Rails and frames to be double dowelled, screwed and glued. Veneer face plywood with solid edges for top / sides / back / drawer faces / door faces.
- Stones to be treated for alcohol and stain resistance where applicable.
- Provide heat and stain resistant finish to top of case goods.
- Ensure that piece will fit in lifts and through doors prior to commencing fabrication. Show all pieces in shop drawings.
- All materials used must be suitable for use in tropical and high humidity areas.
- 30cm.x30cm. finish samples to be provided by manufacturer for approval by LIDG's prior to production.
- 30cm.x30cm. wood and veneer stained finish samples to be submitted by manufacturer for LIDG's approval prior to production.
- Prototype to be provided by manufacturer for approval by LIDG's prior to production.
- All supplied items to be of contract quality, suitable for commercial use.
- Cabinet drawers & doors must be fitted properly aligned and must operate smoothly under various atmospheric conditions. Drawer side-mounted glides to be specified and painted.
- Any marble top must be 20mm. thick with polished edges on exposed sides and must have a tuff skin protective coating.
- All furniture must install non-corrosive, heavy duty, nylon carpet glides to fit the footprint of the leg.

Project :	รพ. ศิริราช ปิยมหาราชการุณย์ กรุงเทพมหานคร ประเทศไทย 15th. FLOOR WARD ROOM	Date :	ISSUED 2020 MAR 02
------------------	--	---------------	------------------------------

MODEL : SY2 5354
GREENLAM ASIA PACIFIC [THAILAND]CO.,LTD.
CONTACT : KATTAREEYA
Tel : 02 294-2569
Fax : 02 294-2568
Mobile : 084 081-1422
E-mail : kattareeya.th@greenlam.com
www.greenlam.com

18 MM.TOP ARTIFICIAL STONE
MODEL : MAE 003 SUPER
RAINBOW ENTERPRISE MARKETING GROUP CO.,LTD. [MASTER QUARTZ BY]
CONTACT : MANATCHANAN
TEL : +66 2 153 8687
FAX : +66 2 153 8687
MOBILE : +66 94 494 9907
E-MAIL : rmg.bkk@gmail.com

MODEL: 1005 CREAMY WHITE
SIAM STYLAM CO.,LTD. [FINENEZZ]
CONTACT : CHITCHANOK
Tax ID : 0105559131937
Mobile : 063 445-3999
E-mail : chitchanok@siamstylam.com
www.siamstylam.com

Item	ตู้ข้างเตียง ในห้องพักรักษาผู้ป่วย	Qty.	1 Nos. /room	Size	W500 X D500X H.700MM.	Source	TO BID
------	------------------------------------	------	--------------	------	-----------------------	--------	--------

Instructions of 3.1 Loose Furniture Specification

Casegoods Furniture (Indoor)

- All wood to be kiln dried and treated to be insect and vermin free.
- All hinges, screws, bolts and other internal hardware to be resistant to corrosion.
- All wood finishes to be stained, full-filled, alcohol, water and burn resistant catalyzed or conversion lacquer finish.
- All exposed and internal wood surfaces to match specified finish.
- Provide heavy duty nylon glides at base/ legs.
- Drawer Slide: Provide full-extension heavy duty drawer slides.
- Construction for consoles, bedside tables, coffee tables, bed frames: Rails and frames to be double dowelled, screwed and glued. Veneer face plywood with solid edges for top / sides / back / drawer faces / door faces.
- Stones to be treated for alcohol and stain resistance where applicable.
- Provide heat and stain resistant finish to top of case goods.
- Ensure that piece will fit in lifts and through doors prior to commencing fabrication. Show all pieces in shop drawings.
- All materials used must be suitable for use in tropical and high humidity areas.
- 30cm.x30cm. finish samples to be provided by manufacturer for approval by LIDG's prior to production.
- 30cm.x30cm. wood and veneer stained finish samples to be submitted by manufacturer for LIDG's approval prior to production.
- Prototype to be provided by manufacturer for approval by LIDG's prior to production.
- All supplied items to be of contract quality, suitable for commercial use.
- Cabinet drawers & doors must be fitted properly aligned and must operate smoothly under various atmospheric conditions. Drawer side-mounted glides to be specified and painted.
- Any marble top must be 20mm. thick with polished edges on exposed sides and must have a tuff skin protective coating.
- All furniture must install non-corrosive, heavy duty, nylon carpet glides to fit the footprint of the leg.

Project :	รพ. ศิริราช ปิยมหาราชการุณย์ กรุงเทพมหานคร ประเทศไทย 15th. FLOOR WARD ROOM	Date :	ISSUED 2020 MAR 02
------------------	--	---------------	------------------------------



SOLID WOOD LEG COLOUR
TO MATCH WOOD VENEER
AS PER SAMPLE
MODEL : SY2 5354

**GREENLAM ASIA PACIFIC
[THAILAND]CO.,LTD.**
CONTACT : KATTAREEYA
Tel : 02 294-2569
Fax : 02 294-2568
Mobile : 084 081-1422
E-mail : kattareeya.th@greenlam.com
www.greenlam.com



VINYL UPHOLSTERY
MODEL : GUARD PUMICE 518634
TITCH Int. Thailand LTD.
TEL: +662 512-4640
FAX: +662 512-4641
CONTACT : นภัทรรัตน์ พงศ์ภูริจินดา
MOBILE : 089-222 8955
E-MAIL : moontitch@gmail.com

Item	เก้าอี้อาหารในห้องพักผู้ป่วย DINING TABLE AT WARD ROOM	Qty.	2 Nos./ RM.	Size	W480 X D520 X H820MM. SEAT HEIGHT 450MM.	Source	DURIFLEX FURNITURE Mobile : +668 1846-1645 Line : 0818461645
-------------	---	-------------	-------------------	-------------	---	---------------	---

Instructions : Seating Furniture (Indoor)

- All wood to be kiln dried and treated to be insect and vermin free.
- All hinges, screws, bolts and other internal hardwares to be resistant to corrosion.
- All wood finished to be stained, full-filled, alcohol, water and burn resistant catalyzed or conversion lacquer finish.
- All internal finishes to match specified finish.
- Polyurethane foam cushions to be flame retardant and must meet local fire codes. Cushion density must be a minimum of 45kg/m3. Cushions must be wrapped with multiple layers of poly Dacron. Use CMHR foam or Code Red foam on all foam core construction.
- Provide heavy duty nylon carpet glides at base/ legs.
- Construction for desk chair, lounge, dining chair: Frame to be constructed of five quarter kiln dried solid hardwood, reinforced with corner blocks, glued and screwed to rail. All rails and posts to be doubled dowelled, screwed and glued in place. Must be of fire retardant construction.
- Ensure that piece will fit in lifts and through doors prior to commencing fabrication. Show all pieces in shop drawings.
- All fabrics to be dimensionally stable and with appropriate backing for upholstery use as recommended by fabric supplier.
- Fabrics upholstery to be flame retardant and meet all applicable codes or at least ASTM E-84 class 'A' on contract quality goods. Warm and humid climate properties must use non-salt based flame proofing to prevent corrosion and mildew of fabrics.
- Fabric used requires a fabric protection treatment, soil / stain resistant finish.
- All fabrics to be delivered in largest bolt / roll possible of first quality only, no seconds, no bolt ends. Fabric to be pre-shrunk, non-fading and non-crooking.
- All materials used must be suitable for use in tropical and high humidity areas.
- 30cm.x30cm. finish samples to be provided by manufacturer for approval by LIDG's prior to production.
- 30cm.x30cm. wood and veneer stained finish samples to be submitted by manufacturer for LIDG's approval prior to production.
- Prototype to be provided by manufacturer for approval by LIDG's prior to production.
- All supplied items to be contract quality, suitable for commercial use.
- All furniture must install non-corrosive, heavy duty, nylon carpet glides to fit the footprint of the leg.

Designer by :

Project :	รพ. ศิริราช ปิยมหาราชการุณย์ กรุงเทพมหานคร ประเทศไทย 15th. FLOOR WARD ROOM	Date :	ISSUED 2020 MAR 02
------------------	---	---------------	------------------------------

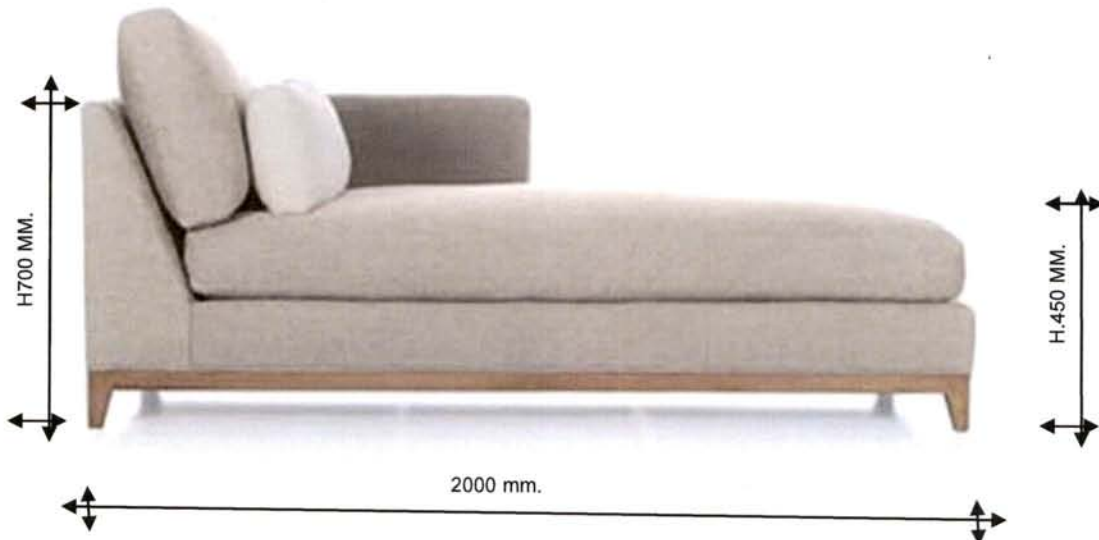

SOLID WOOD LEG COLOUR
TO MATCH WOOD VENEER
AS PER SAMPLE
MODEL : SY2 5354

**GREENLAM ASIA PACIFIC
[THAILAND]CO.,LTD.**
CONTACT : KATTAREEYA
Tel : 02 294-2569
Fax : 02 294-2568
Mobile : 084 081-1422
E-mail : kattareeya.th@greenlam.com
www.greenlam.com



VINYL UPHOLSTERY

MODEL : HOME
P1601-73 BR
TITCH Int. Thailand LTD.
TEL: +662 512-4640
FAX: +662 512-4641
CONTACT : นภัทร์ตราณ์ พงศ์ภูริจินดา
MOBILE : 089-222 8955
E-MAIL : moontitch@gmail.com

Item	โซฟาอนในห้องพักผู้ป่วย SOFA AT WARD ROOM	Qty.	1No/ Rm.	Size	W2000 X D900 X H.700 SEAT HEIGHT : 450 MM.	Source	DURIFLEX FURNITURE Mobile : +668 1846-1645 Line : 0818461645
-------------	---	-------------	-------------	-------------	---	---------------	---

Instructions : Seating Furniture (Indoor)

- All wood to be kiln dried and treated to be insect and vermin free.
- All hinges, screws, bolts and other internal hardwares to be resistant to corrosion.
- All wood finished to be stained, full-filled, alcohol, water and burn resistant catalyzed or conversion lacquer finish.
- All internal finishes to match specified finish.
- Polyurethane foam cushions to be flame retardant and must meet local fire codes. Cushion density must be a minimum of 45kg/m3. Cushions must be wrapped with multiple layers of poly Dacron. Use CMHR foam or Code Red foam on all foam core construction.
- Provide heavy duty nylon carpet glides at base/ legs.
- Construction for desk chair, lounge, dining chair: Frame to be constructed of five quarter kiln dried solid hardwood, reinforced with corner blocks, glued and screwed to rail. All rails and posts to be doubled dowelled, screwed and glued in place. Must be of fire retardant construction.
- Ensure that piece will fit in lifts and through doors prior to commencing fabrication. Show all pieces in shop drawings.
- All fabrics to be dimensionally stable and with appropriate backing for upholstery use as recommended by fabric supplier.
- Fabrics upholstery to be flame retardant and meet all applicable codes or at least ASTM-E-84 class 'A' on contract quality goods. Warm and humid climate properties must use non-salt based flame proofing to prevent corrosion and mildew of fabrics.
- Fabric used requires a fabric protection treatment, soil / stain resistant finish.
- All fabrics to be delivered in largest bolt / roll possible of first quality only, no seconds, no bolt ends. Fabric to be pre-shrunk, non-fading and non-croaking.
- All materials used must be suitable for use in tropical and high humidity areas.
- 30cm.x30cm. finish samples to be provided by manufacturer for approval by LIDG's prior to production.
- 30cm.x30cm. wood and veneer stained finish samples to be submitted by manufacturer for LIDG's approval prior to production.
- Prototype to be provided by manufacturer for approval by LIDG's prior to production.
- All supplied items to be contract quality, suitable for commercial use.
- All furniture must install non-corrosive, heavy duty, nylon carpet glides to fit the footprint of the leg.

Designer by :

Project :	รพ. ศิริราช ปิยมหาราชการุณย์ กรุงเทพมหานคร ประเทศไทย 15th. FLOOR WARD ROOM	Date :	ISSUED 2020 MAR 02
------------------	--	---------------	------------------------------

SOLID WOOD LEG COLOUR
TO MATCH WOOD VENEER
AS PER SAMPLE
MODEL : SY2 5354

GREENLAM ASIA PACIFIC
[THAILAND]CO.,LTD.
CONTACT : KATTAREEYA
Tel : 02 294-2569
Fax : 02 294-2568
Mobile : 084 081-1422
E-mail : kattareeya.th@greenlam.com
www.greenlam.com

VINYL UPHOLSTERY
MODEL : GUARD PUMICE 518634
TITCH Int. Thailand LTD.
TEL: +662 512-4640
FAX: +662 512-4641
CONTACT : นภัทรรัตน์ พงศ์ภูริจินดา
MOBILE : 089-222 8955
E-MAIL : moontitch@gmail.com

Item	เก้าอี้นั่งแต่งตัวในห้องพักผู้ป่วย STOOL AT WARD ROOM	Qty.	1 Nos./ RM.	Size	DIA. 400X450 H630MM. SEAT HEIGHT 450MM.	Source	DURIFLEX FURNITURE Mobile : +668 1846-1645 Line : 0818461645
-------------	--	-------------	-------------------	-------------	--	---------------	---

Instructions : Seating Furniture (Indoor)

1. All wood to be kiln dried and treated to be insect and vermin free.
2. All hinges, screws, bolts and other internal hardwares to be resistant to corrosion.
3. All wood finished to be stained, full-filled, alcohol, water and burn resistant catalyzed or conversion lacquer finish.
4. All internal finishes to match specified finish.
5. Polyurethane foam cushions to be flame retardant and must meet local fire codes. Cushion density must be a minimum of 45kg/m3. Cushions must be wrapped with multiple layers of poly Dacron. Use CMHR foam or Code Red foam on all foam core construction.
6. Provide heavy duty nylon carpet glides at base/ legs.
7. Construction for desk chair, lounge, dining chair: Frame to be constructed of five quarter kiln dried solid hardwood, reinforced with corner blocks, glued and screwed to rail. All rails and posts to be doubled dowelled, screwed and glued in place. Must be of fire retardant construction.
8. Ensure that piece will fit in lifts and through doors prior to commencing fabrication. Show all pieces in shop drawings.
9. All fabrics to be dimensionally stable and with appropriate backing for upholstery use as recommended by fabric supplier.
10. Fabrics upholstery to be flame retardant and meet all applicable codes or at least ASTM E-84 class 'A' on contract quality goods. Warm and humid climate properties must use non-salt based flame proofing to prevent corrosion and mildew of fabrics.
11. Fabric used requires a fabric protection treatment, soil / stain resistant finish.
12. All fabrics to be delivered in largest bolt / roll possible of first quality only, no seconds, no bolt ends. Fabric to be pre-shrunk, non-fading and non-croaking.
13. All materials used must be suitable for use in tropical and high humidity areas.
14. 30cm.x30cm. finish samples to be provided by manufacturer for approval by LIDG's prior to production.
15. 30cm.x30cm. wood and veneer stained finish samples to be submitted by manufacturer for LIDG's approval prior to production.
16. Prototype to be provided by manufacturer for approval by LIDG's prior to production.
17. All supplied items to be contract quality, suitable for commercial use.
18. All furniture must install non-corrosive, heavy duty, nylon carpet glides to fit the footprint of the leg.

Designer by :

3.2 LIGHTING SPECIFICATION

รพ. ศิริราช ปิยมหาราชการุณย์ กรุงเทพมหานคร ประเทศไทย

PROPOSED INTERIOR FIT-OUT

FOR

15th. FLOOR WARD ROOM

Project :	รพ. ศิริราช ปิยมหาราชการุณย์ กรุงเทพมหานคร ประเทศไทย 15th. FLOOR WARD ROOM	Date :	ISSUED 19 MARCH 2020
------------------	---	---------------	--------------------------------

ADDITION 2020-03-19

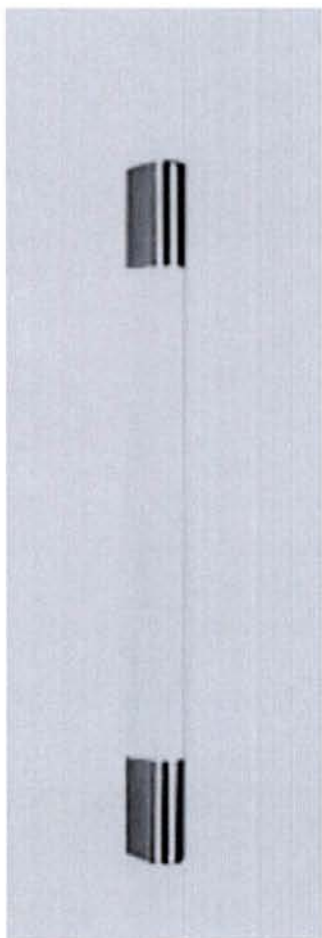

NAVI-600

Product type: Wall lamp
Color: Chrome
Material: Stainless steel, Opal Acrylic
Dimension: W55 X H600 X D65 (mm)
Bulb source: 1*T5 MAX 14W (Bulb not included)
[Product specification](#)

MODEL : NAVI-600
SUPPLIER : LAMPTITUDE.(THAILAND)
CONTACT : MS.JARINYA
TEL : -662 392 1837
FAX : 662 392 1839
MOBILE : 668 6677 3993
E-MAIL : ying@lamptitude.net

* REFER DETAIL TO SUPPLIER *

Item	WALL LAMP AT WARD ROOM	Qty.	-	Size	REFER TO DRAWINGS	Source	LAMPTITUDE
------	---------------------------	------	---	------	-------------------	--------	------------

Instructions: Lighting indoor

1. Fixture to be hardwired.
2. Wattage : To be verified by the lighting consultant.
3. Switches of Floor Lamps and Table Lamps : Switch to be 75 mm from lamp base unless otherwise specified.
4. Cord : Maximum 244 mm clear electrical cord with polarized plug, where applicable.
5. Dimensions are subject to change as a result of perfecting the prototype.
6. To measure on site prior to production.
7. Fixtures must meet all applicable codes.
8. Fixture must be Underwriter's Laboratory (U.L.) approved, and or its local equivalent and wired for use in Local context.
9. All materials used must be suitable for use in tropical and high humidity areas.
10. 15 cm x 15 cm finish samples are to be provided by the manufacturer for approval by LIDG prior to production.
11. Reproducible shop drawings are to be provided by the manufacturer for LIDG's approval prior to production.
12. Prototype of lamp and shade sample are to be provided by the manufacturer for LIDG's approval prior to production.
13. To be internationally wired for use in Local context.
14. Manufacturer to supply all necessary hardware and instructions for installation of fixture.
15. Manufacturer to co-ordinate all wiring requirements for permanent surface mounting and provide hanging / security details for electrician.
16. Fabricator to co-ordinate total weight to the fixture to ensure proper anchoring of fixture to wall or ceiling and any additional blocking required for stability.
17. Owner / Operator to supply exact specifications for local socketing and lamping requirements.
18. General Contractor / ID Contractor to install all lamps including table lamps, console lamps, floor lamps & post lamps except chandeliers to be installed by the manufacturer.
19. Manufacturer warrants all products from all defects and guarantees to replace any, or all parts should they prove deficient within one year from date of owner's acceptance. All costs in this regard shall be borne by the manufacturer.
20. All supplied items must be of contract quality & suitable for commercial use.

Designer by :

3.3 TEXTILE SPECIFICATION

รพ. ศิริราช ปิยมหาราชการุณย์ กรุงเทพฯ ประเทศไทย

PROPOSED INTERIOR FIT-OUT

FOR

15th. FLOOR WARD ROOM

INTERIOR ARCHITECTURE
DESIGNER

LEOINTER

39th Floor Ocean Tower II Building

75/108 -109 Sukhumvit 19 Road, Klongtoey Nua, Vadhana, Bangkok 10110, Thailand.

Tel : +66 (0) 2261 7733 Fax : +66 (0) 2261 7734 Email : lidg@lidg.co.th

Project :

รพ. ศิริราช ปิยมหาราชการุณย์ กรุงเทพฯ ประเทศไทย
15th. FLOOR WARD ROOM

Date :

ISSUED
2020 MAR 02

LOOSEGOODS SPECIFICATION DATA SHEET

CONTENTS

3.3 TEXTILE SPECIFICATION

CURTAIN

CUR-01	ม่านกันเสียง CURTAIN FOR BED AREA AT WARD ROOM	3.3 - 01
CUR-02	ม่านหน้าต่าง CURTAIN AND SHEER FOR WINDOW AT WARD ROOM	3.3 - 02

Project :	รพ. ศิริราช ปิยมหาราชการุณย์ กรุงเทพมหานคร ประเทศไทย 15th. FLOOR WARD ROOM	Date :	ISSUED 28 FEBRUARY 2020
------------------	---	---------------	-----------------------------------

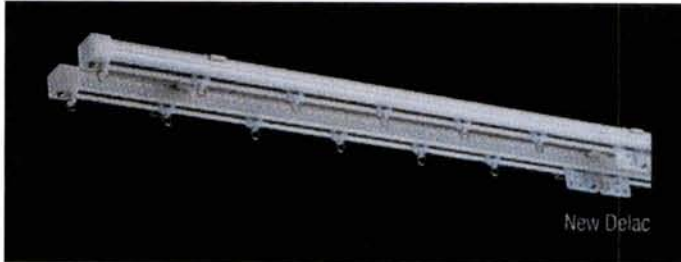

CURTAIN TRACKS

MODEL : NEW DELAC
COLOUR : CHROME
TODAYSTYLE2100 CO.,LTD.
TEL.: 02 321 4232-4
FAX: 02 721 3389
E-MAIL: info@todaystyle2100.com
http://www.todaystyle2100.com

CURTAIN HOOK REFER TO SUPPLIER

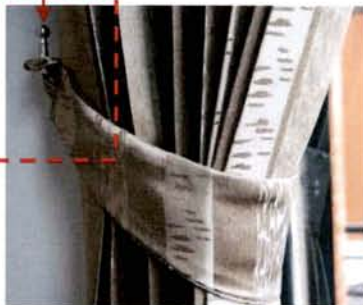

**หมายเหตุ : เพิ่มผ้าหุ้มโซ่ที่ปลายม่าน

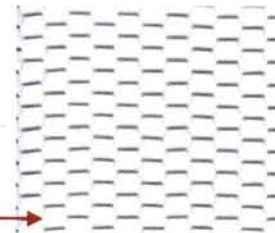
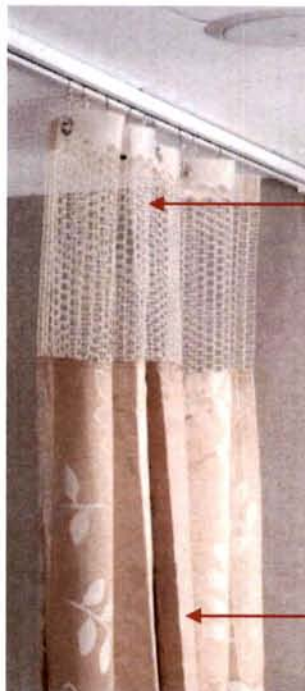

TX-01 FABRIC FOR CURTAIN

DESIGN : GALIZE – 155 LE56 /WIDTH : 50"
SUPPLIER : FABRISIGNER CO.,LTD.
CONTACT : MS.THANYARAT O.
TEL : 662 948 4205
FAX : 662 948 4206
MOBILE : 668 9811 9473
E-MAIL : fabisigner@hotmail.com

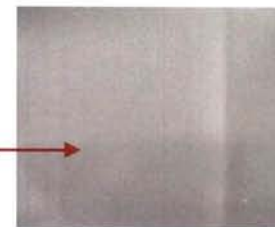

TX-02 FABRIC FOR CURTAIN

DESIGN: CHACHACHA / ELEPHANT
WIDTH : 292 CM.
SUPPLIER : PASAYA CO.,LTD.(THAILAND)
CONTACT : MS.KRITIKA
TEL : 662 440 0955
FAX : 662 440 0933-4
MOBILE : 668 9054 5455
E-MAIL : kritika@pasaya.com

Item	ม่านกันเตียง	Qty.	Size	REFER TO DRAWINGS	Source	BEST IN HOME DECORATION
	CURTAIN FOR BED AREA AT WARD RM.					CONTACT : MS.DAWNAPA TEL : 086 331-3216

Instructions :

- Ceiling mounted with secret clamp: Straight hung double pleat drapery (200% fullness) , split at centre, traverse drawn. Double pleated curtain with reinforced corner stitching, sewn with a matching blackout.
- Over drapery lined fullness must be twice the width of the opening when measured across the finished hem plus overlaps and returns. This equates to 200 percent for Pinch Pleat drapery fabrication.
- Fabricator / Supplier to verify required quantity of fabric inclusive of lining if any.
- Designated Fabricator to provide for installation and heavy duty hardware.
- New curtain tracks (2 Kirsch Architect #94004 baton drawn tracks with ball bearing carriers on similar hardware). Dia9.5mm x H1000mm pulling rod with pocket detail to be provided.
- Curtain to cover entire window with finished length of 5mm above floor finished level.
- All patterned drapery widths are to be patterned match, starting from the bottom.
- All drapery bottom hem with 100mm doubled and blind stitched. Bottom hem to be weighted.
- All side hems with 40mm doubled and blind stitched. All headings with 100mm doubled with a non-woven buckram.
- All hardware and pin hooks to be rust proof material.
- Fabric used requires a fabric protection treatment, soil / stain resistant finish.
- Fabric must use non-salt based flameproofing to prevent corrosion and mildew of fabrics.
- Fabric to compile the British Standards or meet other equivalent codes for 'Medium Hazard' category of the Hotel's standard requirements.
- All fabrics to be delivered in largest bolt / roll possible of first quality only, no seconds, no bolt ends. Fabric to be pre-shrunk, non-fading and non-croaking.
- Fabric must be contract quality and suitable for commercial use.
- All batons must be heavy duty and installed on the front of panels 42" / 1.07 m AFF

Designer by :

Project :	รพ. ศิริราช ปิยมหาราชการุณย์ กรุงเทพมหานคร ประเทศไทย 15th. FLOOR WARD ROOM	Date :	ISSUED 28 FEBRUARY 2020
------------------	---	---------------	-----------------------------------



CURTAIN HOOK REFER TO SUPPLIER

TX-01 FABRIC CURTAIN
MODEL : ABUZZ /COL : 10258-05
WIDTH/57" FR TEST-NFPA701
TEST1 - 2015 EDITION
PHROMLIKHIT LUCK CO.,LTD.
CONTACT : MR. CHOTTANA
TEL : 087 702-9944
MOBILE : 084 769-6666
E-MAIL : phromluck@gmail.com

TX-02 SHEER FABRIC CURTAIN
MODEL : ZLEEK COL : IVORY
WIDTH :293CM.
SUPPLIER: PASAYA CO.,LTD.(THAILAND)
CONTACT : MS.KRITIKA
TEL : 662 440 0955
FAX : 662 440 0933-4
MOBILE : 668 9054 5455
E-MAIL : kritika@pasaya.com

****หมายเหตุ : เพิ่มผ้าหุ้มโซ่ที่ปลายม่าน ส่วนตัว**
BLACK OUT ติดตั้งตุ๊กแกสามารถถอดออกได้

Item	ม่านหน้าต่าง	Qty.	Size	REFER TO DRAWINGS	Source	BEST IN HOME DECORATION
	CURTAIN AND SHEER FOR WINDOW AT WARD ROOM					CONTACT : MS.DAWNAPA TEL : 086 331-3216

Instructions :

- Ceiling mounted with secret clamp: Straight hung double pleat drapery (200% fullness) , split at centre, traverse drawn. Double pleated curtain with reinforced corner stitching, sewn with a matching blackout.
- Over drapery lined fullness must be twice the width of the opening when measured across the finished hem plus overlaps and returns. This equates to 200 percent for Pinch Pleat drapery fabrication.
- Fabricator / Supplier to verify required quantity of fabric inclusive of lining if any.
- Designated Fabricator to provide for installation and heavy duty hardware.
- New curtain tracks (2 Kirsch Architect #94004 baton drawn tracks with ball bearing carriers on similar hardware). Dia9.5mm x H1000mm pulling rod with pocket detail to be provided.
- Curtain to cover entire window with finished length of 5mm above floor finished level.
- All patterned drapery widths are to be patterned match, starting from the bottom.
- All drapery bottom hem with 100mm doubled and blind stitched. Bottom hem to be weighted.
- All side hems with 40mm doubled and blind stitched. All headings with 100mm doubled with a non-woven buckram.
- All hardware and pin hooks to be rust proof material.
- Fabric used requires a fabric protection treatment, soil / stain resistant finish.
- Fabric must use non-salt based flameproofing to prevent corrosion and mildew of fabrics.
- Fabric to compile the British Standards or meet other equivalent codes for 'Medium Hazard' category of the Hotel's standard requirements.
- All fabrics to be delivered in largest bolt / roll possible of first quality only, no seconds, no bolt ends. Fabric to be pre-shrunk, non-fading and non-croaking.
- Fabric must be contract quality and suitable for commercial use.
- All batons must be heavy duty and installed on the front of panels 42" / 1.07 m AFF

Designer by :